

# ATLAS

MADE IN GERMANY. SINCE 1919.

# ATLAS 155W Bigfoot



---

**OPERATING WEIGHT**

**15.4 -16.5 T**

---

**ENGINE POWER**

**115 KW**

---

**BUCKET CAPACITY**

**0.7 - 1.0 M<sup>3</sup>**

---

# ATLAS. FOR HIGHER EFFICIENCY.

Experience more than 100 years of expertise: robust perfection, high-grade details, and well-engineered functionality. As a competent and highly efficient manufacturer of premium construction machinery in Germany, ATLAS develops loader cranes, excavators, and material handlers **as well as customized, individual special solutions**. ATLAS is the construction machine for toughest applications and for all who are looking for uncompromising quality.

**ATLAS POWER OF INNOVATION.  
MADE IN GERMANY.**

"For more than a century, our highly motivated employees devote themselves every day with unfailing dedication to the design and assembly of tailor-made excavators and cranes which serve to significantly speed up your working processes and make them more efficient. Our dedication is reflected in working tenaciously every day in order to create innovative solutions. This tradition, which extends over generations, is proof of our continuous commitment to developing high-quality machines which meet the ever-changing requirements and challenges of our time."



**Brahim Stitou, CEO**



100 Years  
Bigfoot



# BUILT TO MOVE BIG THINGS.

**CUSTOMIZED SOLUTIONS FOR A GREAT FUTURE.  
ECO-FRIENDLY, VERSATILE, AND PERFECTLY FUNCTIONAL.  
ATLAS CONSTRUCTION MACHINERY MADE IN GERMANY  
– FOR MORE THAN 100 YEARS SECOND TO NONE.**

**// Whatever we tackle, it will be impressive!**

From our 100-year history, we have learned: we think big and implement it. Our secret to success lies in the combination of efficiency, technological supremacy, and in-depth discussions with customers. This makes our construction machinery so versatile and strong! From standard model all the way to custom-made design – we have the best solution for any challenge.

State-of-the-art ideas and innovative concepts are the foundation for construction machines, which meet the highest standards in a wide range of applications.

Once again, the result is impressive: our strong, sturdy, and stable wheeled excavator ATLAS 155W Bigfoot. An excavator like no other.

<b>OPERATING WEIGHT</b>	<b>15.4-16.5 T</b>
<b>ENGINE POWER</b>	<b>115 KW</b>
<b>BUCKET CAPACITY</b>	<b>0.7-1.0 M<sup>3</sup></b>

# THAT'S WHAT AN ATLAS IS ALL ABOUT.

## HIGHER EFFICIENCY

Perfectly aligned components make the powerful engine run at top performance. The 155W Bigfoot impresses by its **long service life, low fuel consumption, and best performance.** Tremendously stable in value – for life.

## USER-FRIENDLY SERVICE

When developing the ATLAS 155W Bigfoot, we already thought about maintenance. **Readily accessible service points** reduce downtime as well as maintenance cost and allow for easy and cost-effective retrofitting should the need arise. **The optional telemetric system** provides all relevant data of the machine.

## UNIQUE UNDERCARRIAGE DESIGN

Striking design. Highest ground clearance with strong torsion resistance. The unique undercarriage construction in conjunction with a powerful traction motor ensures the **outstanding stability** as well as a **convincing off-road capability.** Powerful and persuasive; won't let you down not even in most severe conditions. Use of 22to class heavy-duty axles.

## BIGFOOT TIRES IN SIZE 710/45-26.5" 20 PR

ATLAS is the only manufacturer with these extremely large special tires. With their impressive traction, they are ready to tackle any terrain. No matter if you go through muddy paths or driving in rocky areas, these tires provide the safety and performance you need.

## OPTIMUM SAFETY

A large cab door and non-slip steps ensure **safer access to the cab.** We also thought of the **cab lighting.** Needless to say that all precautionary measures are incorporated into the cab design for that extra bit of **safety according to ROPS & FOPS.**

## POWERFUL HYDRAULICS

With the efficient hydraulics, excavator drivers can demonstrate with the **power** of an ATLAS 155W Bigfoot that they have what it takes: perform demanding tasks **fast at full capacity.** Thus, when **precision** is required, sensitive work movements become a manageable task. Under load as well.

## HIGH MACHINE AVAILABILITY

This ingenious combination of **high-quality components** ensures reliable performance. All are nicely boxed thanks to the **robust design.** And the **telemetric system** provides all relevant data to prevent the project from coming to a halt.

## AXLES

Our heavy-duty axle sets new standards in off-road application. Thanks to their robust construction and high-performance tires you effortlessly master the most demanding types of terrain.

## COMFORTABLE CAB

Our best cab with the perfect combination of clearly arranged controls, operating comfort, and health protection! It features **360° panoramic view** for higher safety, **air conditioning** to keep your cool and for clean air as well as an **ergonomically adjustable seat** to reduce work fatigue.

## WORKING EQUIPMENT FROM IN-HOUSE MANUFACTURING

**In-house manufacturing** allows for **great flexibility** and a choice of individual solutions – exactly to customer request. **The quick-change device** originates from own production as well.



# COMPACT. AGILE. AND QUIET.



## BEST MANEUVERABILITY IN THE MOST CONFINED SPACES

With an agile 1.98-meter swing radius, this multi-talent is perfectly suited for any job. Whether in difficult terrain or the most confined construction sites, the 155W Bigfoot sets new standards in terms of maneuverability. **This puts it at the very top of its class!**



## BOOM WITH VARIOUS WORKING LENGTHS

Always ahead by the ideal working length! The 155W Bigfoot can be used in a wide range of applications. From short booms for precise operation to longer booms for greater reach, ATLAS excavators adapt to any needs. This way, no challenge remains out of reach!



## LOW NOISE LEVEL – BOTH INSIDE AND OUTSIDE

The special soundproofing for more quiet inside the cab provides for better concentration and health protection. Our bearings and engines emit only a minimum of sound and the noise level, both inside and at the outside, is very low.



1.98 meters

Smallest swing radius  
Of its class!

# A LEADING EDGE IN EVERY DETAIL.

**ADMITTEDLY, WE ARE A BIT PROUD. THE ATLAS 155W BIGFOOT IS THE TAILOR-MADE RESPONSE TO CUSTOMER REQUESTS AND FUTURE REQUIREMENTS. MANY YEARS OF PASSIONATE DEVELOPMENT WORK WENT INTO THIS POWER PACKAGE.**

Our goal: besides allowing for productivity increases, better environmental compatibility as well as superior safety, we aimed to create a powerful and, at the same time, maneuverable construction machine in a compact format. With the ATLAS 155W Bigfoot we achieved this! This means that we are again taking the lead for "standard tailor-made" solutions.

Its essence is robust and responsive, maneuverable and stable, comfortable and yet safe. Driven by uncompromising quality standards, we left nothing to chance.

To the smallest detail, from boom to accessories, we think things through to the end. And these details are highly impressive!



## UNOBSTRUCTED VIEW

### // Cab with 360° panoramic view

The large-scale glazing of the cab with a very large front window, undivided side windowpanes and a low-slung rear window offers the driver an unobstructed 360° view of the working environment. Thus, the workplace becomes an ergonomic and safe area and facilitates precise operation.



### // Rear view camera

The standard rear and side-view camera monitor the side and rear area. Especially during rotary motions of the machine, in particular in confined spaces, the camera provides enhanced safety.



### // Easy to read camera display

A clearly arranged, uncluttered and easy to read camera display – without unnecessary details – provides superior view and control.

---

## EASY ACCESS FOR SERVICE

---



### // Easy maintenance

A service-oriented machine set-up ensures short maintenance times and minimizes the maintenance costs involved. **All service points**, such as measuring points, filter exchange or cleaning of cooling surfaces, **are readily accessible** and, thanks to the large wide-opening service doors, they can be easily reached.

---

## LIKE CLOCKWORK

---



### // Central lubrication points

All necessary lubrication areas are easily accessible and clearly visible as well – so that service will also be fun in future.

---

## READY-TO-HAND

---



### // Trailer-hitching device

The trailer-hitching device allows for towing of trailers up to 3 tons, with overrun brake even up to 8 tons. This way, the complete tools and the required equipment can be taken along to the job site.

---

## STOWED WELL

---



### // Tools always on board

For quick use on site, all kinds of tools are stowed ergonomically arranged in the toolbox on the undercarriage.

---

## EFFICIENT OPERATION

---



### // Automatic working brake (Option)

Thanks to the automatic working brake, work can start immediately after stopping. Service brake and axle blocking are automatically activated as soon as the machine is stationary.

# FEEL. GOOD. CAB.

**WELCOME TO ONE OF THE WORLD'S MOST COMFORTABLE WORK-PLACES, WELCOME TO OUR CAB. WITH 360-DEGREE PANORAMIC VIEW, EASY TO READ APPLIANCES, LOW NOISE LEVEL, AND WELL-CONCEIVED VENTILATION AND ERGONOMICS CONCEPT.**

Get on board, feel good, and get started! The driver's cab on the ATLAS 155W Bigfoot, the maneuverable powerhouse, could make others jealous of one of the nicest workstations in the world.

Special emphasis is placed on clear arrangement, driver's health as well as comfortable usability. Via non-slip steps and a wide access, you enter the spacious cab. Here, the machine operator watches over the projects from a premium driver's seat!

The seat is ergonomically designed, made from premium materials, and available in various designs – individually adjustable of course, while the pneumatic suspension and lumbar support ensure a high level of seat comfort. Seat heating and headrest are a must as well!

From the seat, everything a driver needs for the job is within easy reach. Ranging from the adjustable control panel and the ergonomically formed joystick, all control levers and panels are within reach. The automatic climate control not only provides for cooling on hot workdays but also ensures supply of clean, dust-free air, and in wintertime it keeps warm. Via the display, temperature, fan and air-conditioning can easily be controlled.

All control instruments in this state-of-the-art and well-equipped cab are clearly arranged.

One also cannot too strongly emphasize the large-scale glazing for superior panoramic view. For a safe and good feeling. Throughout the full, sometimes long workday!







**YOUR WORKSTATION  
OF TOMORROW.  
ALREADY TODAY.**



**// Multifunctional panel**

Small, clearly arranged and made for quick access. The optimized design of the push buttons and switches help to avoid mistakes.



**// Air conditioning**

Fresh air keeps the head fresh and the respiratory passages clear from dust! This is created by the well-thought out ventilation system.



**// Monitor with side and rear view camera**

The monitor ensures maximum safety thanks to a better view – in particular during rotary movements and operation in confined spaces.



**// Smartphone tray with USB port**

Life without smartphone? Inconceivable! In order to keep our digital all-rounder safe, it gets prominent place on the smartphone tray.



**// Comfortable operation via joystick**

Reduced to the essential elements for intuitive operation, the joystick moves ergonomically with the seat – and fits any hand.



**// Bottle holder**

With the bottle holder within comfortable reach, the thirst quencher is always close at hand and yet stowed well and safely!



**// Cooler box (Option)**

Perfect for between-meal snacks: the integrated cooler box with electrical hook-up keeps the day's provisions optimally stowed.



**// Non-slip flooring**

Always a firm grip underfoot, even when speed is of the essence: the non-slip flooring prevents the driver from sliding.



**// Front window stowable**

The lower part of the front window is removable and can easily be stowed. This allows for uncomplicated and direct communication by shouting, for example, to the mate at work in the trench. In addition, it ensures an unrestricted view into the building pit.





ATLAS

36

36

155W blue

ATLAS

BIG FOOT

MICHAELIS

## ENGINE



### Deutz // TCD 4.1 L4 – intelligent and efficient

Since ATLAS was established, we are convinced of the quality of Deutz engines. This is why the water-cooled 4-cylinder inline engine with turbocharging and with charge air-cooling and exhaust after-treatment (EAT) is the key component of the 155W Bigfoot, too. The powerful Deutz Common-Rail (DCR®) high-pressure injection system and electronic engine control (EMR 5) with smart connection to the drive management ensure highest engine performance at lowest consumption.

### // Compliance with emission standards:

EU-stage 5 and US EPA Tier 4 with DOC / DPF / SCR TIER IV final and the EU-stage 5.

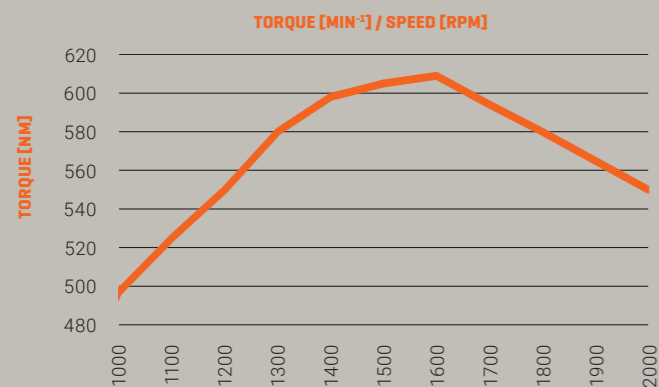

## HYDRAULIC SYSTEM



### Bosch Rexroth

The hydraulic system ensures quick response times by providing maximum utilization of the available engine performance and yet, the Bosch Rexroth hydraulic system provides movements independent of the load via an electronically controlled pump and load-independent flow distribution (LUDV). This intelligent performance control ensures high flow distribution, combined with proportional work functions.

For enhanced efficiency, the work speed can always be adjusted to the operating conditions – by freely selectable and adjustable work modes. For maximum operating performance, a power boost is available as well.

## AXLES



### ZF

The combination of frame, axles and transmission offer a perfect output of power at enhanced stability – due to the proven selection of quality products and the ideal positioning of the components. The robust frame structure ensures higher uptime and a long service life of the machine.

The heavy-duty axle design is excellently suited for driving across difficult terrain. The pendulum axle can be controlled automatically or connected manually.

## ATTACHMENT TOOLS



### ATLAS

ATLAS offers a wide range of attachment tools for the most diverse requirements – and this **from in-house production!**

This provides you with plenty of benefits:

**Very wear-resistant** – thanks to the use of high-tensile steels and a solid construction.

**Maximum efficiency** – all attachment tools are specifically designed for your excavator model and will fit perfectly.

**Certified** – according to the applicable safety standards

**Guaranteed** – with full warranty coverage and support

**Added value** – enhanced resale value

And apart from that: The use of high-quality attachment tools may contribute to reduce fuel consumption and emissions, which in turn sustainably preserves our environment.

## SLEWING RING



### Thyssen Krupp – Rothe Erde

Thanks to internal gearing and sealed ball bearings, the ball bearing slewing ring from Rothe Erde is an ideal and, at the same time, cost-effective solution.

The design is resistant to major torque fluctuations at all times.



Scan QR code to go directly to **attachment tools:**

# TECHNICAL DATA

## ENGINE

Gross power (ISO 14396)	115 kW
Net power (ISO 9249)	110 kW
Model	Deutz TCD 4.1 L4 EU Stage V
Type	Turbocharger/intercooling
Displacement	4038 cm <sup>3</sup>
Number of cylinders	4
Bore/cylinder stroke	101 / 126
Cooling system	water-cooled
Air filter	Dry air filter
Battery	2 x 12 V / 100 Ah
Generator	24 V / 100 A
Starter	24 V / 4 kW
Standard Basic equipment	automatic idling system/ engine stop cold-starting aid Diesel pre-filter Engine monitoring

## HYDRAULIC SYSTEM

AWE 5 System (Load Sensing)	
Load limit controlled high-performance pump	
Fuel-efficient flow-on-demand control	
Sensitive, proportional, independent control	
Primary and secondary protection against overload	
Suction valves for all work functions	
Break protection for lift and adjustment cylinders	
Proportional grab and grab rotating function	
Three additional circuits for auxiliary consumers possible max. 260 l/min flowrate	
max. 320 bar operating pressure	
Cylinder end position damping	
Operating modes	F1 (Fine) F2 (Eco) F3 (Power)
Accumulator for emergency lowering of the arm system	
Load-limit control	

## SLEWING GEAR

Axial piston motor with priority valve	
Planetary transmission	
Automatically controlled multi-disc parking brake	
Two-stage valves	
Slewing torque	34 kNm
Upper structure rotation speed	8/min

## TRAVEL DRIVE + BRAKES

Variable speed drive motor	
Powershift transmission	
Double-acting brake valve	
Travel direction pre-selection via switch on joystick	
Automotive traveling and cruise control	
Max. speed	20 km/h
Off-road speed	5 km/h
Crawling speed	3.7 km/h
Traction	82 kN
Gradeability	55 %
Dual-circuit brake system	multi-disc
Parking brake	multi-disc

## UNDERCARRIAGE

Steering axle with automatic pendulum axle locking	
Additional axle locking via left joystick	
Heavy-duty axles	
Toolbox at undercarriage	
STD tires: 4-road tires 710/45 - 26.5	

## VIBRATION EMISSION \*

Hand-arm-vibrations	< 2.5 m/s <sup>2</sup>
Whole-body vibrations	< 0.5 m/s <sup>2</sup>
Measurement uncertainty according to standard EN 12096:1997	

\*For assessment of hazard exposure acc. to 2002/44/EG, see ISO/TR 25398:2006

## DRIVER'S CAB

Meets the latest safety standard (ROPS)	
Extra-wide access	
Ample legroom	
Radio kit with mute function	
Installation kit for thermoelectric cooler	
Various storage options, document compartment	
Thermal insulating glazing, windows tinted	
Excellent panoramic view	
Driver's seat	Comfort seat with headrest Arm rests and lumbar support Seat adjustable independent of console Air suspended Heated Horizontal and vertical suspension Lumbar support
Control	Ergonomic joysticks with proportional slide Slim steering column with adjustable height and tilt Switches neatly arranged on the control panel Pendulum axle locking on the left joystick
Monitoring	Operating data indication via display Automatic monitoring, warning, and storage Rear area monitoring camera Side-view camera, right-hand side
Air-conditioning	automatic climate control Excellent air distribution due to optimally arranged nozzles Refrigerant R134a
Sound level	ISO 6396 (LpA) inside driver's cab: 69 dB(A) 2000/14 EG (LwA) ambience level: 96 dB(A)

## TIRES (OPTIONAL)

8-fold set of tires 215/70 R22.5 Caliber Power Grip 23
--

## FILLING QUANTITIES

Fuel tank	240 liters
Cooling system	35 liters
Engine oil	10 liters
Hydraulic tank capacity	125 liters
Hydraulic system capacity	200 liters
Ad Blue®	20 liters

## OPERATING WEIGHTS\*

ADJUSTABLE BOOM	
Loading boom 1.95 m (C3.41)   Boom 3.07 m (C346)	
Support dozer blade	Stick 1.96 m 15.4 - 16.9 t
ADJUSTABLE BOOM	
Loading boom 1.95 m (C3.41)   Boom 3.57 m (C346.1)	
Support dozer blade	Stick 2.50 m 15.7 - 16.2 t
ADJUSTABLE BOOM	
Loading boom 1.95 m (C3.41)   Boom 3.57 m (C346.1)	
Support dozer blade	Stick 3.00 m 15.8 - 16.3 t

\*Operating weight incl. driver, machine filled, and 1 ton for attachment tools

## ATTACHMENT TOOLS (SELECTION)

	Capacity SAE	Cutting width
Bucket F415	0.67 m <sup>3</sup>	850 mm
Bucket F418	0.92 m <sup>3</sup>	1100 mm
Ditching bucket G644	0.56 m <sup>3</sup>	2000 mm



# ACCESSORY EQUIPMENT

**IT'S WORTH IT: OUR ATLAS ACCESSORY EQUIPMENT FOR EXTRA COST-EFFECTIVENESS AND SAFETY.**

## FOR MORE EFFICIENCY

- Refueling pump
- Rotating beacon
- Transmission protection
- Rockfall safety guard
- Hydraulic adapter kit,  
Stabilizers can be operated for each axle separately
- Wheel cover
- Cab elevation
- Patented trailer hitch
- Bio-oil
- Sprinter 36 km/h

## DRIVER'S COMFORT

- Automatic working brake
- Proportional control of stabilizers via slider on joystick
- Synchronous electrical central lubrication system with monitoring function for upper structure and boom equipment
- Joystick steering
- 270° camera system
- LED working lights
- Driver's seat Premium (Actimo Evolution)
- Electric cooler
- Radio with USB port and Bluetooth
- Buzzer alert for drive mode
- Auxiliary heater with water circuit
- GPS/GSM telemetry box for monitoring of operating data, consumption, position

## FOR ADDITIONAL ACCESSORY EQUIPMENT, SEE PRICE LIST

## SPECIAL SOLUTIONS ON REQUEST

The picture shows customized equipment.

**ROAD TRAVEL CONFIGURATION**

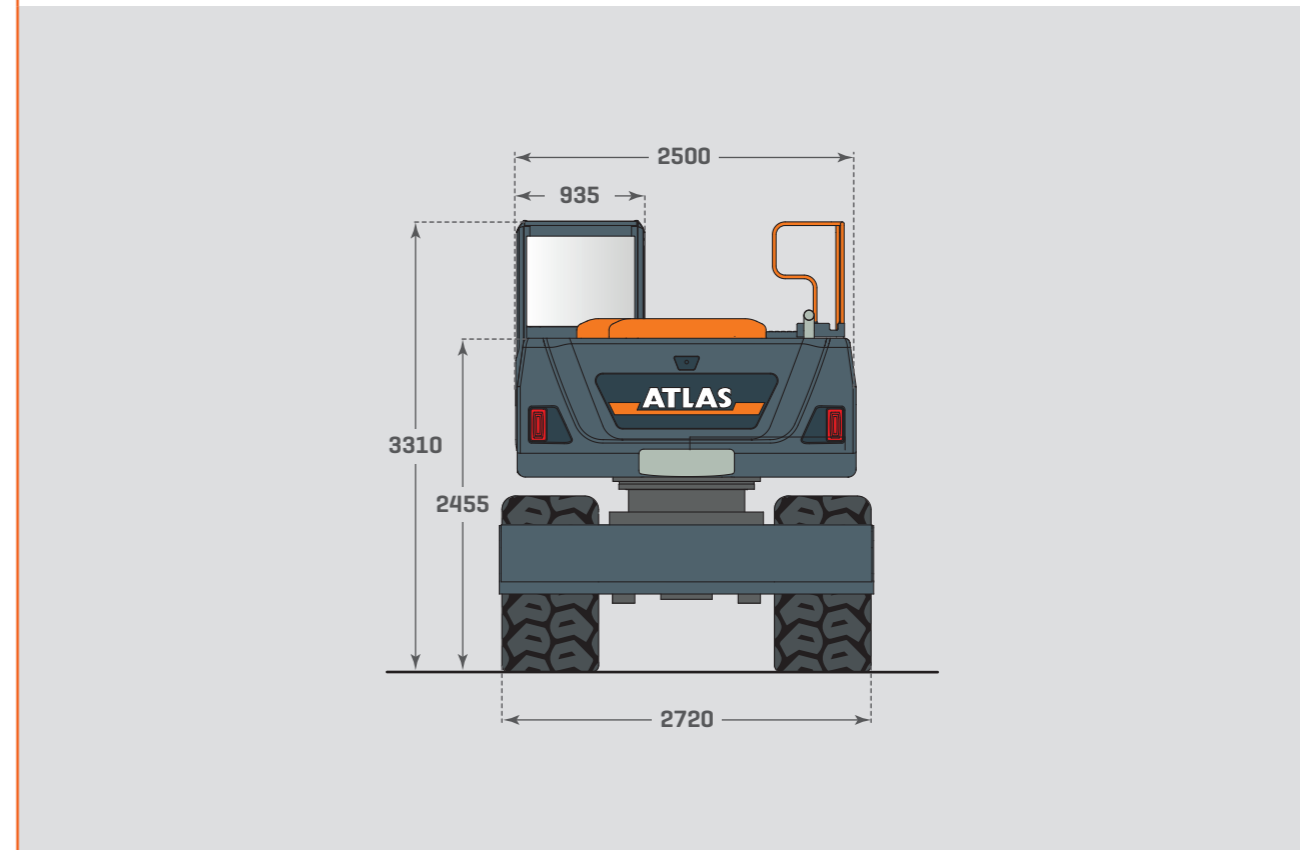
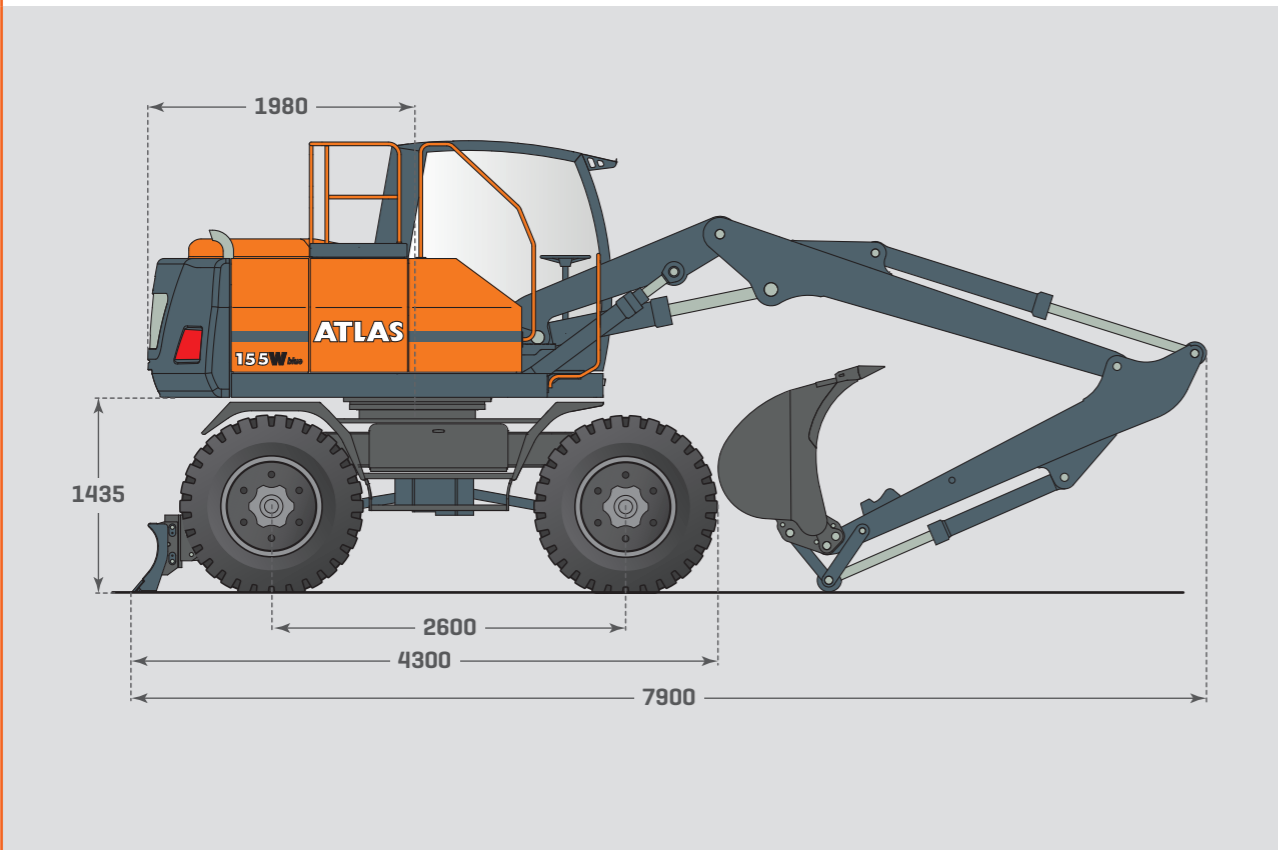

**TRANSPORT HEIGHT (WITH BUCKET)**

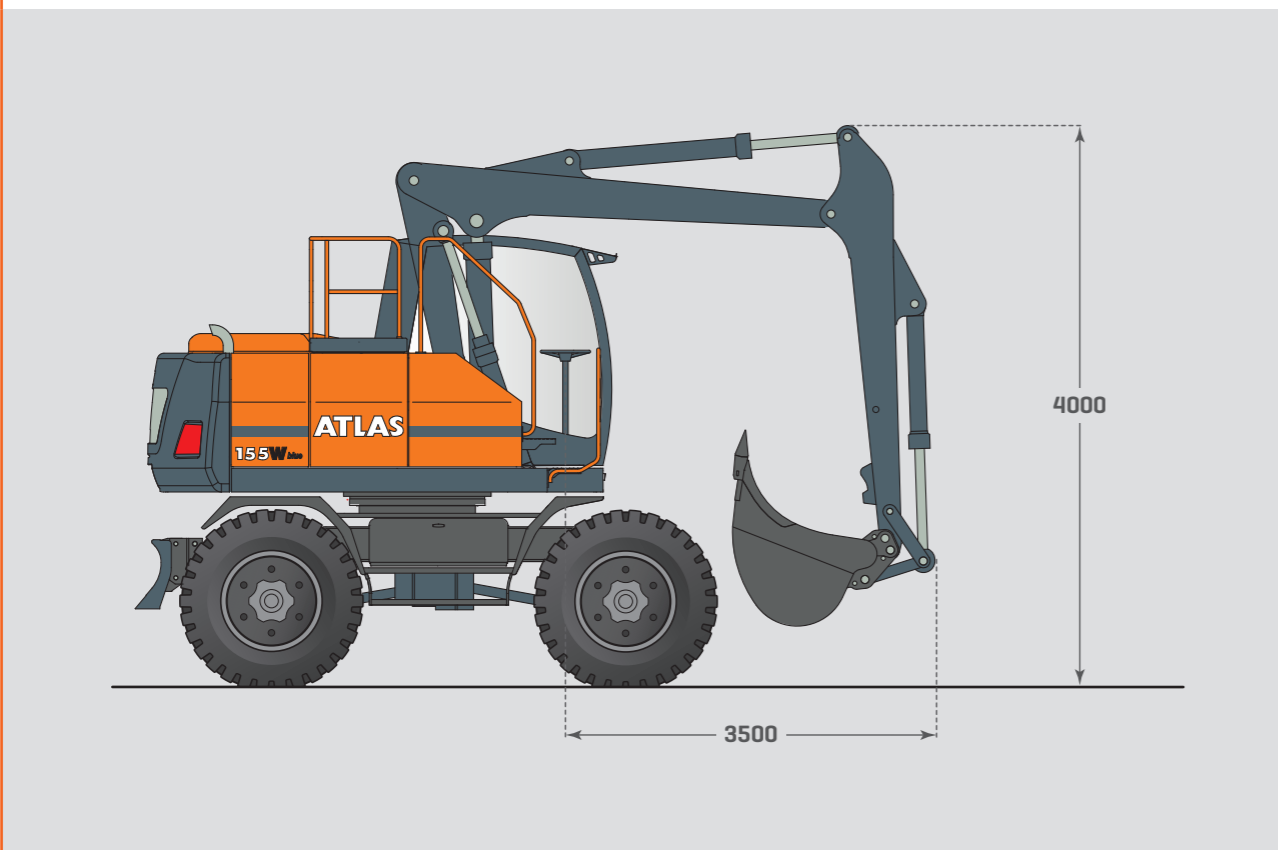

**A155W.2.BF**

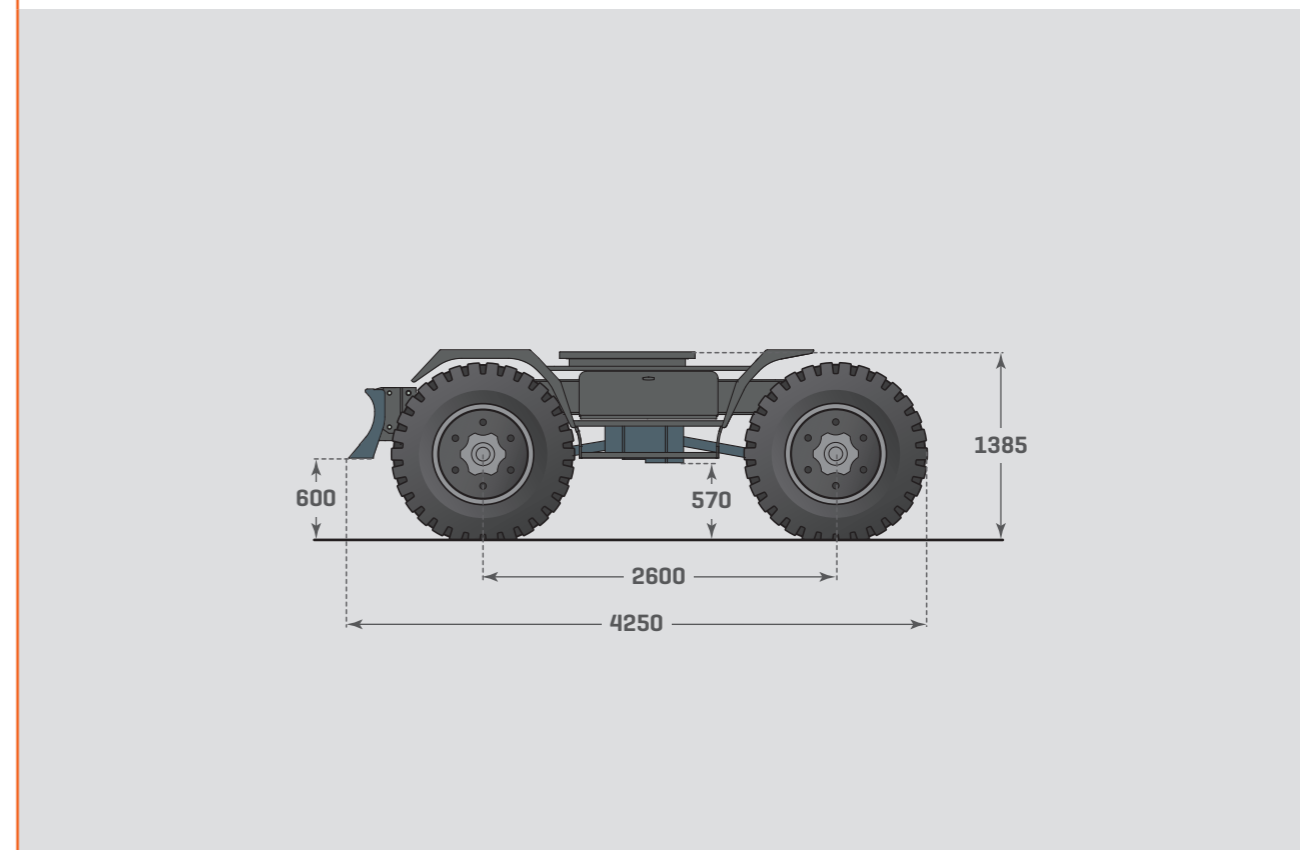

# TURNING RADIUS

AXLE ZF 3060, TIRE 710 / 26,5"

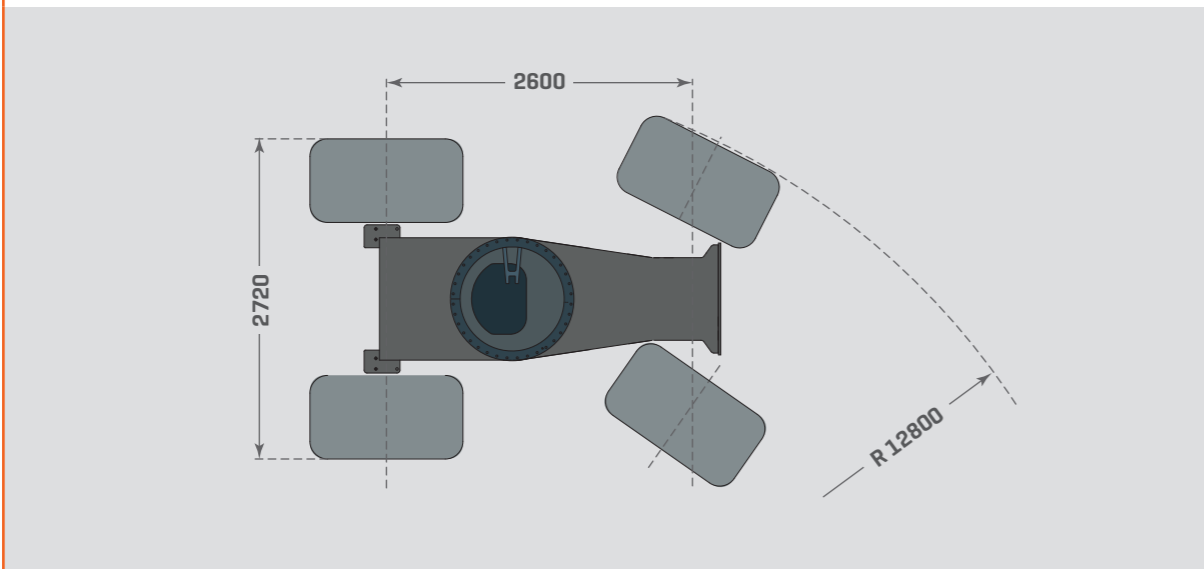

# BOOMS & ARMS

## ADJUSTMENT EQUIPMENT

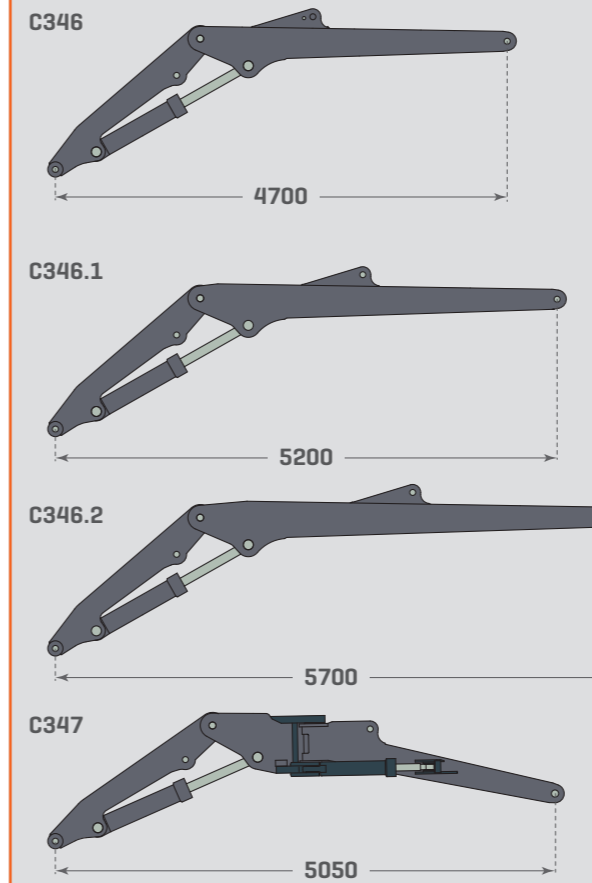

## MONOARM

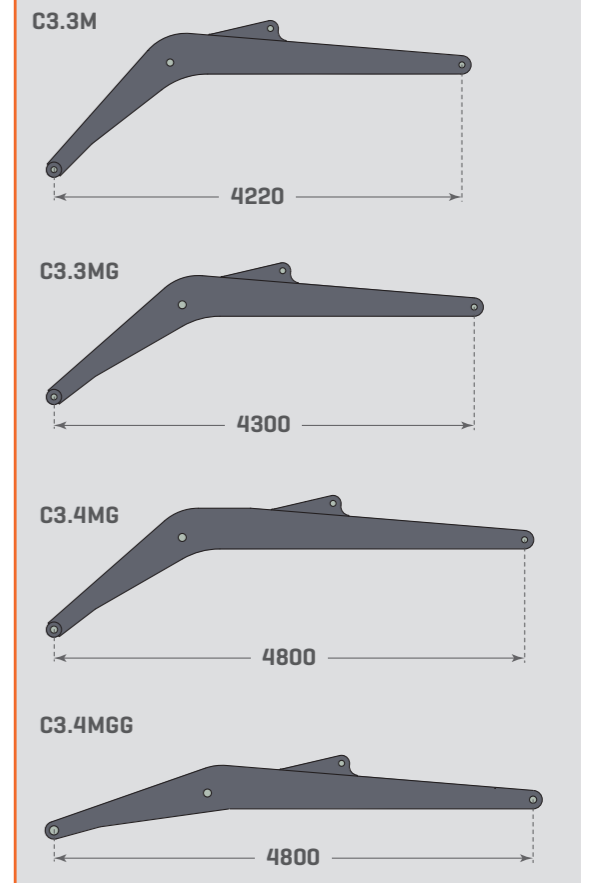

## STICKS

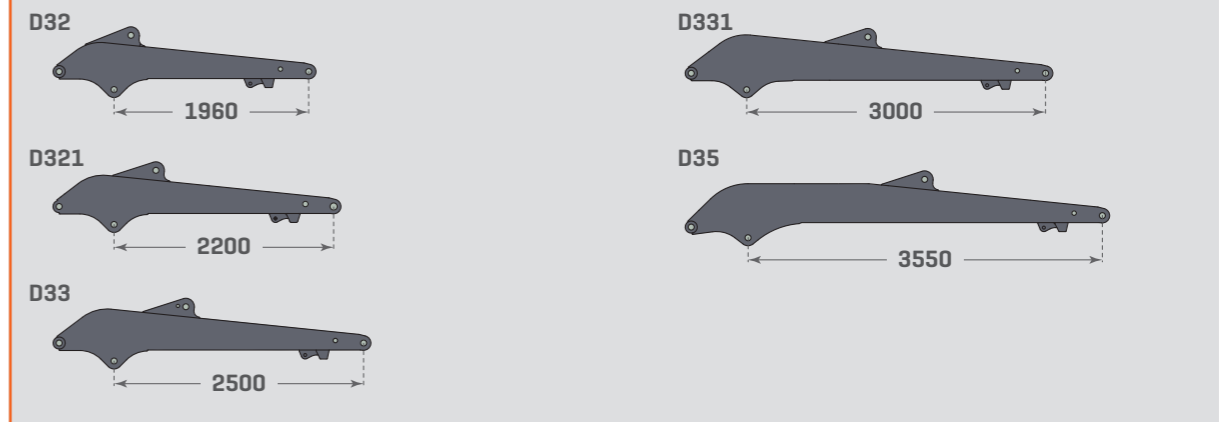



### DIGGING EQUIPMENT WITH ADJUSTABLE BOOM 5.05 M, STICK 2.2 M

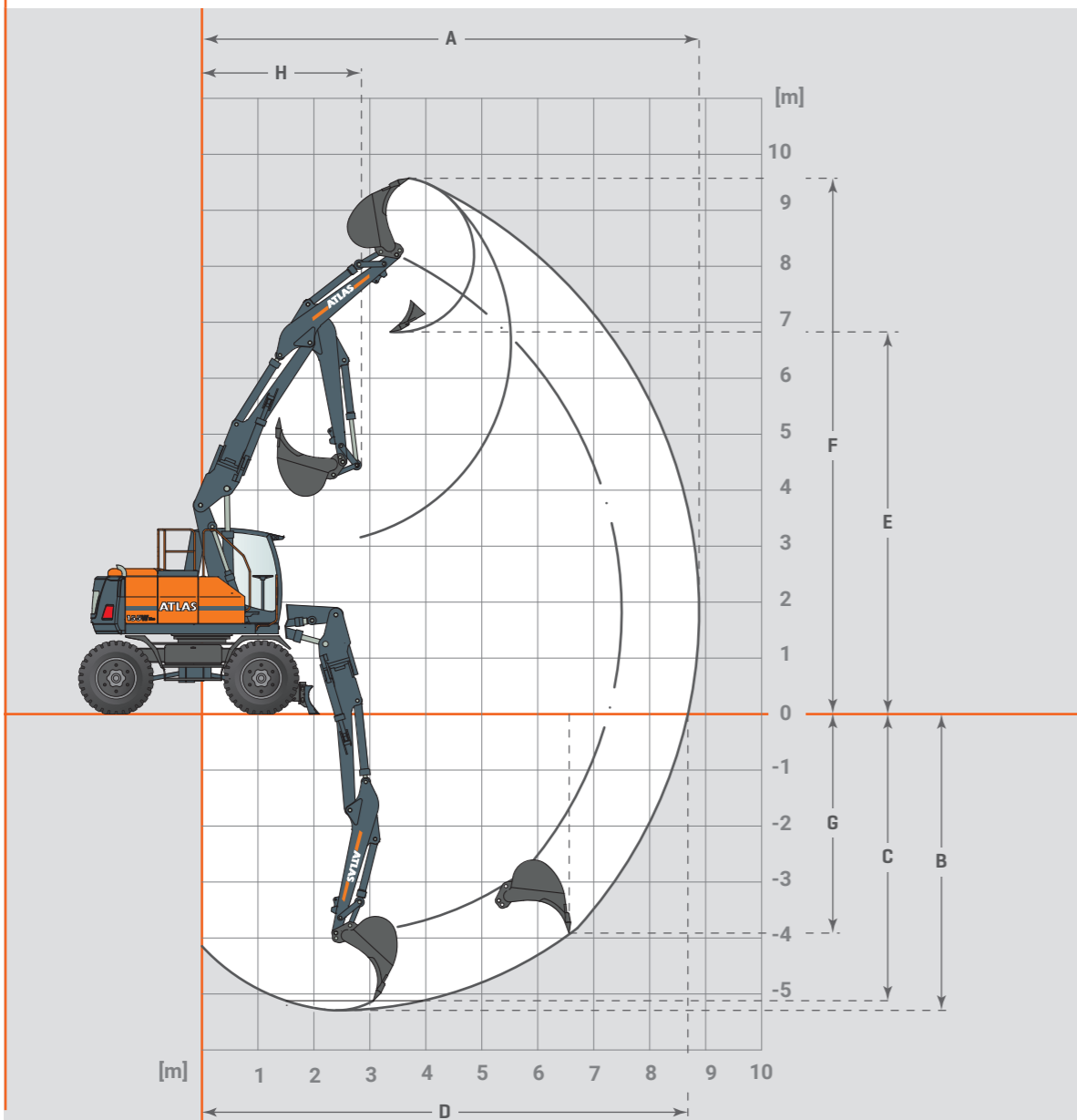

### ADJUSTABLE BOOM C3.41, C347, STICK D321

Dipper stick length 2.2 m		
A	max. Reach	8.900 mm
B	max. Digging depth	5.300 mm
C	max. Digging depth (l=2.44 m level)	5.150 mm
D	max. Reach at ground level	8.700 mm
E	max. Dumping clearance	6.850 mm
F	max. Digging reach	9.600 mm
G	max. Vertical digging depth	3.900 mm
H	min. Front swing radius	2.850 mm
	max. Tear-out force	60 KN
	max. Breakout force	100 KN

### INFO BOX

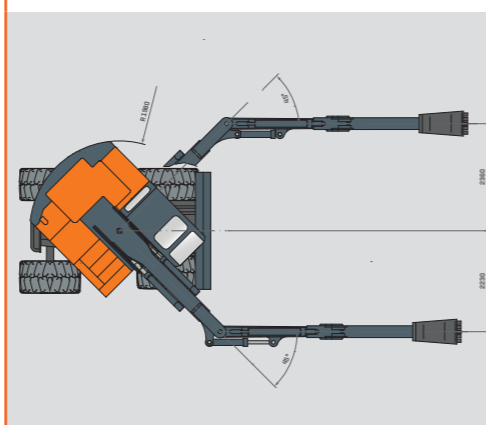

### LOAD CAPACITY WITH ADJUSTABLE BOOM 5.05 M, STICK 2.2 M | AXLE STANDARD

	Front	Rear	2 m			3 m			4 m			5 m			6 m			7 m		
			L	Q+	Q	L	Q+	Q	L	Q+	Q	L	Q+	Q	L	Q+	Q	L	Q+	Q
7 m	Blade											3.3*	3.3*	3.3*						
6 m	Blade											3.1*	3.1*	3.1*	3.0*	3.0*	2.6			
5 m	Blade										3.7*	3.7*	3.7*	3.2*	3.2*	3.2*	2.9*	2.9*	2.7	
4 m	Blade					5.4*	5.4*	5.4*	4.0*	4.0*	4.0*	3.4*	3.4*	3.4*	3.0*	3.0*	2.7	2.7*	2.3	2.0
3 m	Blade					5.6*	5.6*	5.6*	4.7*	4.7*	4.7*	3.7*	3.7*	3.5	3.1*	3.1	2.7	2.8*	2.3	2.0
2 m	Blade					6.3*	6.3*	6.3*	5.2*	5.2*	4.6	3.9*	3.9*	3.5	3.3*	3.1	2.6	2.8*	2.3	1.9
1 m	Blade		11.5*	11.5*	11.5*	7.4*	7.4*	7.0	5.4*	5.4*	4.6	4.1*	4.0	3.4	3.3*	2.9	2.5	2.8*	2.2	1.9
0 m	Blade		13.1*	13.1*	13.1*	7.6*	7.6*	6.9	5.4*	5.3	4.5	4.1*	3.8	3.3	3.4*	2.8	2.4	2.8*	2.2	1.8
-1 m	Blade		13.2*	13.2*	13.2*	7.7*	7.7*	6.6	5.4*	5.1	4.3	4.2*	3.7	3.1	3.4*	2.7	2.3	2.5*	2.1	1.8
-2 m	Blade		13.5*	13.5*	13.1	7.9*	7.9	6.4	5.6*	5.0	4.2	4.3*	3.5	2.9	3.1*	2.6	2.2			
-3 m	Blade		13.4*	13.4*	13.2	7.9*	7.8	6.3	5.2*	4.8	4.0	3.5*	3.4	2.9						
-4 m	Blade		9.1*	9.1*	9.1*	5.2*	5.2*	5.2*												

### LOAD CAPACITY WITH ADJUSTABLE BOOM 5.05 M, STICK 2.2 M | AXLE WIDE

	Front	Rear	2 m			3 m			4 m			5 m			6 m			7 m		
			L	Q+	Q	L	Q+	Q	L	Q+	Q	L	Q+	Q	L	Q+	Q	L	Q+	Q
7 m	Blade											3.3*	3.3*	3.3*						
6 m	Blade											3.1*	3.1*	3.1*	3.0*	3.0*	2.8			
5 m	Blade											3.7*	3.7*	3.7*	3.2*	3.2*	2.9	2.9*	2.9	
4 m	Blade					5.4*	5.4*	5.4*	4.0*	4.0*	4.0*	3.4*	3.4*	3.4*	3.0*	3.0*	2.9	2.7*	2.5	2.2
3 m	Blade					5.6*	5.6*	5.6*	4.7*	4.7*	4.7*	3.7*	3.7*	3.7*	3.1*	3.1*	2.9	2.8*	2.5	2.2
2 m	Blade					6.3*	6.3*	6.3*	5.2*	5.2*	5.1	3.9*	3.9*	3.8	3.3*	3.3*	2.9	2.8*	2.5	2.1
1 m	Blade		11.5*	11.5*	11.5*	7.4*	7.4*	7.4*	5.4*	5.4*	5.1	4.1*	4.1*	3.8	3.3*	3.2	2.7	2.8*	2.5	2.1
0 m	Blade		13.1*	13.1*	13.1*	7.6*	7.6*	7.6*	5.4*	5.4*	4.9	4.1*	4.1*	3.6	3.4*	3.1	2.6	2.8*	2.4	2.0
-1 m	Blade		13.2*	13.2*	13.2*	7.7*	7.7*	7.4	5.4*	5.4*	4.7	4.2*	4.1	3.4	3.4*	3.0	2.5	2.5*	2.4	2.0
-2 m	Blade		13.5*	13.5*	13.5*	7.9*	7.9*	7.2	5.6*	5.6	4.6	4.3*	3.9	3.3	3.1*	2.9	2.5			
-3 m	Blade		13.4*	13.4*	13.4*	7.9*	7.9*	7.1	5.2*	5.2*	4.4	3.5*	3.5*	3.2						
-4 m	Blade		9.1*	9.1*	9.1*	5.2*	5.2*	5.2*												



L = longitudinally unsupported



Q+ = laterally supported

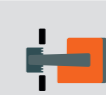

Q = laterally unsupported

Lift capacities in tons (T) at the articulated jib end, without bucket tipping cylinder, without tool. Values on level ground, locked pendulum axle, and pressure switched on. Values laterally to the undercarriage apply throughout 360° rotatable. The values Laterally 1) apply supported. The values longitudinally to the undercarriage apply supported across the rigid axle as well as unsupported across the steering axle. The indicated load values are stated according to ISO 10567, imply a stability of 25% and are calculated at 87% of the maximum hydraulic lifting capacity. An asterisk (\*) marks the values that are limited by hydraulic lifting capacity.

## DIGGING EQUIPMENT WITH ADJUSTABLE BOOM 5.2 M, STICK 2.5 M

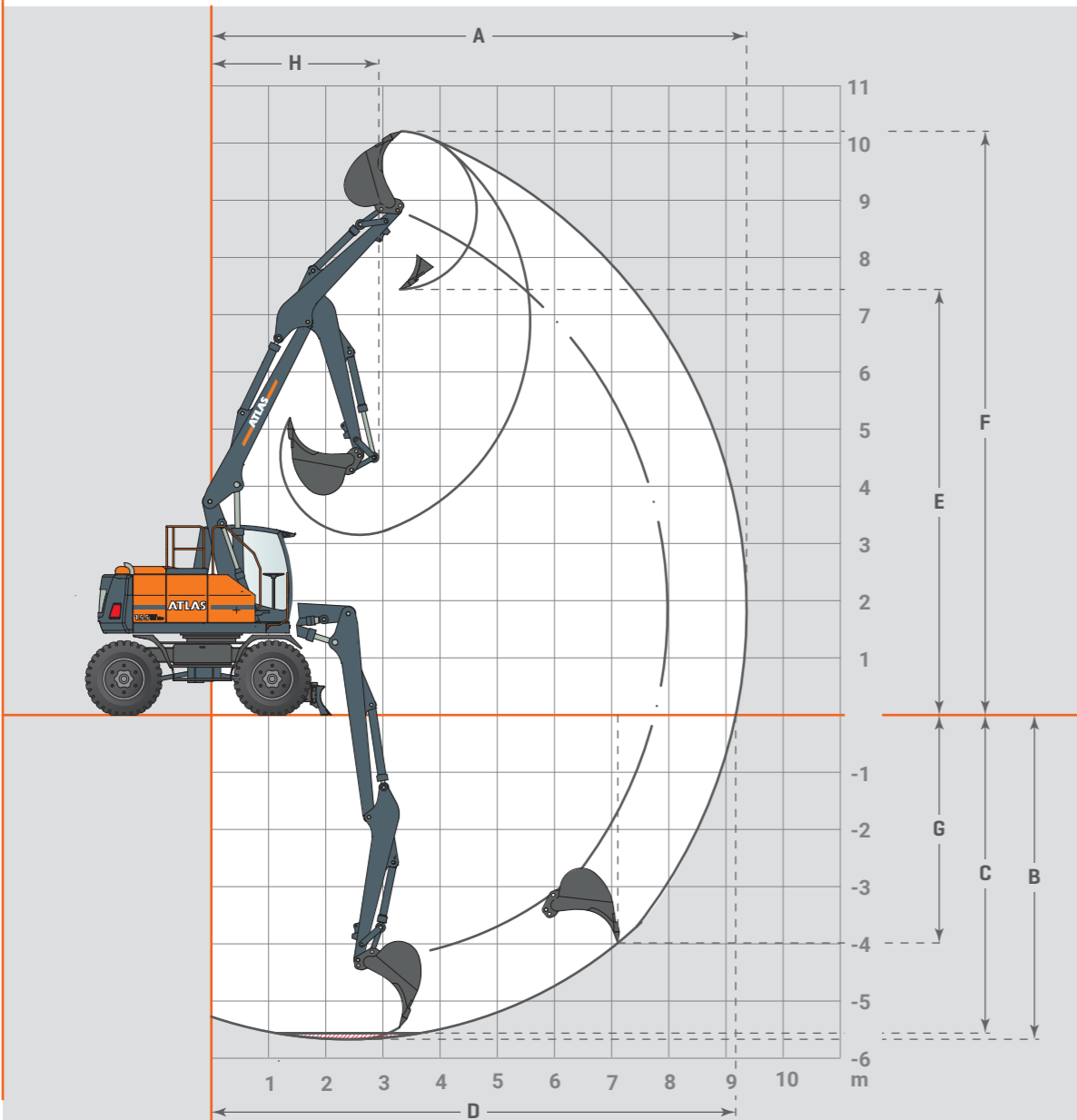

### ADJUSTABLE BOOM C3.41, C346.1, STICK D33

Dipper stick length 2.5 m		
A	max. Reach	9.400 mm
B	max. Digging depth	5.700 mm
C	max. Digging depth (I=2.44 m level)	5.600 mm
D	max. Reach at ground level	9.200 mm
E	max. Dumping clearance	7.450 mm
F	max. Digging reach	10.200 mm
G	max. Vertical digging depth	4.000 mm
H	min. Front swing radius	2.950 mm
	max. Tear-out force	55 KN
	max. Breakout force	100 KN

### INFO BOX

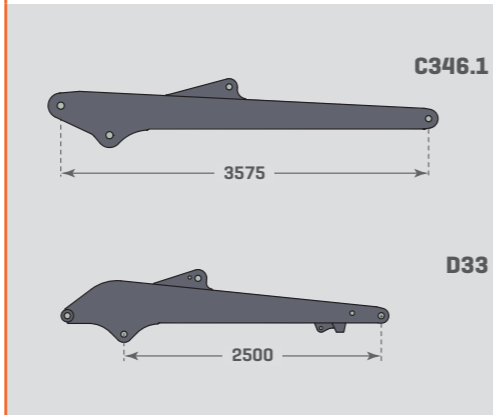

## LOAD CAPACITY WITH ADJUSTABLE BOOM 5.2 M, STICK 2.5 M | AXLE STANDARD

	Front	Rear	2 m			3 m			4 m			5 m			6 m			7 m		
			L	Q+	Q	L	Q+	Q	L	Q+	Q	L	Q+	Q	L	Q+	Q	L	Q+	Q
8 m	Blade							3.7*	3.7*	3.7*										
7 m	Blade										3.1*	3.1*	3.1*							
6 m	Blade										3.1*	3.1*	3.1*	2.9*	2.9*	2.7				
5 m	Blade							3.7*	3.7*	3.7*	3.2*	3.2*	3.2*	2.9*	2.9*	2.7	2.7*	2.4	2.1	
4 m	Blade					5.4*	5.4*	5.4*	4.2*	4.2*	4.2*	3.5*	3.5*	3.5	3.0*	3.0*	2.7	2.8*	2.4	2.1
3 m	Blade					5.3*	5.3*	5.3*	4.8*	4.8*	4.7	3.8*	3.8*	3.5	3.2*	3.2	2.7	2.8*	2.4	2.1
2 m	Blade					6.1*	6.1*	6.1*	5.3*	5.3*	4.6	4.0*	4.0	3.4	3.3*	3.1	2.7	2.9*	2.4	2.0
1 m	Blade		10.9*	10.9*	10.9*	7.4*	7.4*	7.0	5.5*	5.4	4.5	4.2*	4.0	3.4	3.4*	3.0	2.6	2.9*	2.3	2.0
0 m	Blade		13.3*	13.3*	13.3*	7.8*	7.8*	6.8	5.5*	5.3	4.5	4.2*	3.8	3.3	3.5*	2.9	2.5	2.9*	2.3	1.9
-1 m	Blade		13.4*	13.4*	13.3	7.9*	7.9*	6.6	5.6*	5.1	4.3	4.3*	3.7	3.2	3.5*	2.8	2.4	2.9*	2.2	1.9
-2 m	Blade		13.7*	13.7*	13.4	8.1*	7.9	6.5	5.7*	5.1	4.3	4.4*	3.7	3.1	3.5*	2.8	2.4	2.3*	2.2	1.9
-3 m	Blade		13.9*	13.9*	13.5	8.2*	7.9	6.4	5.8*	5.0	4.2	4.2*	3.6	3.0	2.7*	2.7*	2.3			
-4 m	Blade		11.8*	11.8*	11.8*	7.0*	7.0*	6.5	4.5*	4.5*	4.1									

## LOAD CAPACITY WITH ADJUSTABLE BOOM 5.2 M, STICK 2.5 M | AXLE WIDE

	Front	Rear	2 m			3 m			4 m			5 m			6 m			7 m		
			L	Q+	Q	L	Q+	Q	L	Q+	Q	L	Q+	Q	L	Q+	Q	L	Q+	Q
8 m	Blade							3.7*	3.7*	3.7*										
7 m	Blade										3.1*	3.1*	3.1*							
6 m	Blade										3.1*	3.1*	3.1*	2.9*	2.9*	2.9*				
5 m	Blade							3.7*	3.7*	3.7*	3.2*	3.2*	3.2*	2.9*	2.9*	2.9*	2.7*	2.6	2.2	
4 m	Blade					5.4*	5.4*	5.4*	4.2*	4.2*	4.2*	3.5*	3.5*	3.5*	3.0*	3.0*	3.0	2.8*	2.6	2.2
3 m	Blade					5.3*	5.3*	5.3*	4.8*	4.8*	4.8*	3.8*	3.8*	3.8	3.2*	3.2*	3.0	2.8*	2.6	2.2
2 m	Blade					6.1*	6.1*	6.1*	5.3*	5.3*	5.1	4.0*	4.0*	3.7	3.3*	3.3*	2.9	2.9*	2.6	2.2
1 m	Blade		10.9*	10.9*	10.9*	7.4*	7.4*	7.4*	5.5*	5.5*	5.0	4.2*	4.2*	3.7	3.4*	3.3	2.8	2.9*	2.5	2.2
0 m	Blade		13.3*	13.3*	13.3*	7.8*	7.8*	7.6	5.5*	5.5*	4.9	4.2*	4.2	3.6	3.5*	3.2	2.8	2.9*	2.5	2.1
-1 m	Blade		13.4*	13.4*	13.4*	7.9*	7.9*	7.4	5.6*	5.6*	4.7	4.3*	4.1	3.5	3.5*	3.1	2.7	2.9*	2.4	2.1
-2 m	Blade		13.7*	13.7*	13.7*	8.1*	8.1*	7.3	5.7*	5.6	4.7	4.4*	4.0	3.4	3.5*	3.1	2.6	2.3*	2.3*	2.1
-3 m	Blade		13.9*	13.9*	13.9*	8.2*	8.2*	7.2	5.8*	5.6	4.6	4.2*	4.0	3.3	2.7*	2.7*	2.5			
-4 m	Blade		11.8*	11.8*	11.8*	7.0*	7.0*	7.0*	4.5*	4.5*	4.5*									

Lift capacities in tons (T) at the articulated jib end, without bucket tipping cylinder, without tool. Values on level ground, locked pendulum axle, and pressure switched on. Values laterally to the undercarriage apply throughout 360° rotatable. The values Laterally 1) apply supported. The values longitudinally to the undercarriage apply supported across the rigid axle as well as unsupported across the steering axle. The indicated load values are stated according to ISO 10567, imply a stability of 25% and are calculated at 87% of the maximum hydraulic lifting capacity. An asterisk (\*) marks the values that are limited by hydraulic lifting capacity.



## DIGGING EQUIPMENT WITH ADJUSTABLE BOOM 5.2 M, STICK 3.0 M

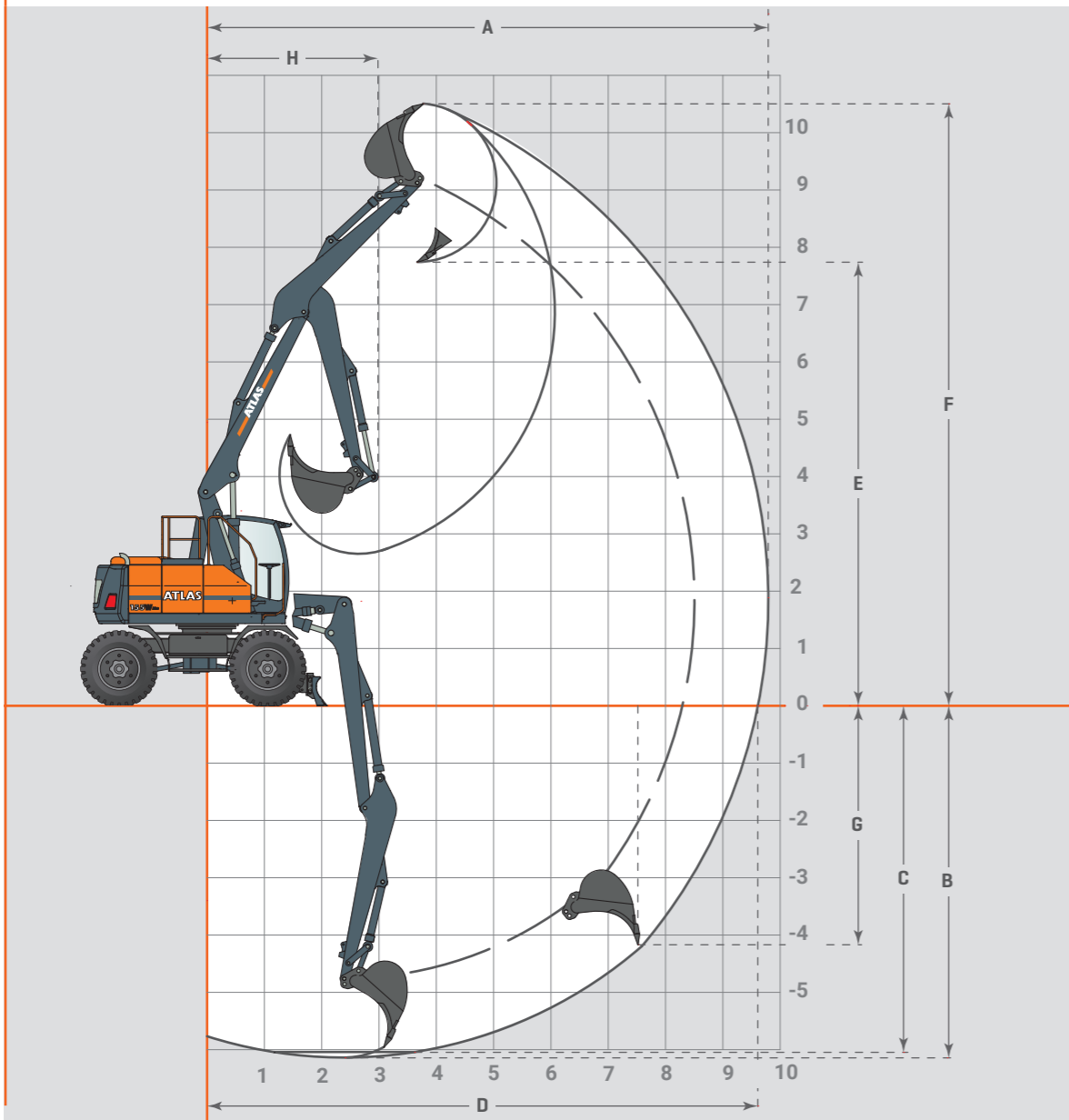

### ADJUSTABLE BOOM C3.41, C346.1, STICK D331

Dipper stick length 3.0 m		
A	max. Reach	9.800 mm
B	max. Digging depth	6.200 mm
C	max. Digging depth (l=2.44 m level)	6.050 mm
D	max. Reach at ground level	9.650 mm
E	max. Dumping clearance	7.750 mm
F	max. Digging reach	10.500 mm
G	max. Vertical digging depth	4.200 mm
H	min. Front swing radius	2.950 mm
	max. Tear-out force	50 KN
	max. Breakout force	100 KN

### INFO BOX

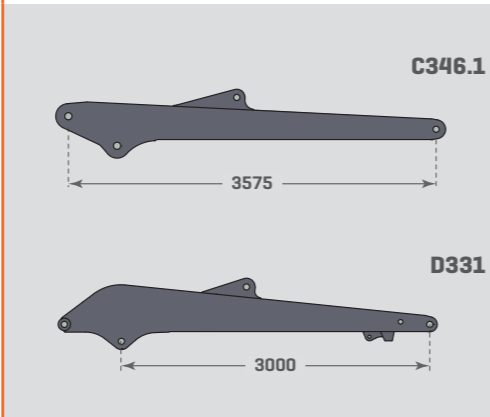

## LOAD CAPACITY WITH ADJUSTABLE BOOM 5.2 M, STICK 3.0 M | AXLE STANDARD

	Front	Rear	3 m			4 m			5 m			6 m			7 m			8 m		
			L	Q+	Q	L	Q+	Q	L	Q+	Q	L	Q+	Q	L	Q+	Q	L	Q+	Q
8 m	Blade							3.0*	3.0*	3.0*										
7 m	Blade							2.8*	2.8*	2.8*	2.7*	2.7*	2.7							
6 m	Blade							2.7*	2.7*	2.7*	2.7*	2.7*	2.7*	2.5*	2.4	2.1				
5 m	Blade							2.9*	2.9*	2.9*	2.7*	2.7*	2.7*	2.6*	2.5	2.1				
4 m	Blade					3.9*	3.9*	3.9*	3.2*	3.2*	3.2*	2.8*	2.8*	2.7	2.6*	2.5	2.1	2.4*	1.9	1.6
3 m	Blade		5.4*	5.4*	5.4*	4.3*	4.3*	4.3*	3.5*	3.5*	3.5	3.0*	3.0*	2.7	2.7*	2.5	2.1	2.4*	1.9	1.6
2 m	Blade		6.2*	6.2*	6.2*	5.0*	5.0*	4.5	3.8*	3.8*	3.4	3.2*	3.1	2.7	2.8*	2.4	2.1	2.4*	1.9	1.6
1 m	Blade		7.4*	7.4*	6.9	5.4*	5.4*	4.5	4.1*	3.9	3.4	3.4*	3.1	2.6	2.8*	2.4	2.0	2.5*	1.9	1.6
0 m	Blade		7.7*	7.7*	6.8	5.4*	5.4	4.5	4.2*	3.9	3.3	3.4*	3.0	2.5	2.9*	2.3	2.0	2.4*	1.8	1.5
-1 m	Blade		7.7*	7.7*	6.6	5.4*	5.1	4.3	4.2*	3.7	3.2	3.4*	2.9	2.5	2.9*	2.2	1.9			
-2 m	Blade		7.9*	7.8	6.3	5.5*	5.0	4.2	4.3*	3.7	3.1	3.5*	2.8	2.4	2.8*	2.2	1.9			
-3 m	Blade		8.1*	7.9	6.4	5.7*	5.0	4.2	4.4*	3.6	3.0	3.3*	2.7	2.3						
-4 m	Blade		7.9*	7.9*	6.5	5.3*	4.9	4.1	3.7*	3.5	3.0									

## LOAD CAPACITY WITH ADJUSTABLE BOOM 5.2 M, STICK 3.0 M | AXLE WIDE

	Front	Rear	3 m			4 m			5 m			6 m			7 m			8 m		
			L	Q+	Q	L	Q+	Q	L	Q+	Q	L	Q+	Q	L	Q+	Q	L	Q+	Q
8 m	Blade							3.0*	3.0*	3.0*										
7 m	Blade							2.8*	2.8*	2.8*	2.7*	2.7*	2.7*							
6 m	Blade							2.7*	2.7*	2.7*	2.7*	2.7*	2.7*	2.5*	2.5*	2.3				
5 m	Blade							2.9*	2.9*	2.9*	2.7*	2.7*	2.7*	2.6*	2.6*	2.3				
4 m	Blade					3.9*	3.9*	3.9*	3.2*	3.2*	3.2*	2.8*	2.8*	2.8*	2.6*	2.6*	2.3	2.4*	2.1	1.8
3 m	Blade		5.4*	5.4*	5.4*	4.3*	4.3*	4.3*	3.5*	3.5*	3.5*	3.0*	3.0*	2.9	2.7*	2.7*	2.3	2.4*	2.1	1.8
2 m	Blade		6.2*	6.2*	6.2*	5.0*	5.0*	5.0*	3.8*	3.8*	3.7	3.2*	3.2*	2.9	2.8*	2.7	2.3	2.4*	2.1	1.8
1 m	Blade		7.4*	7.4*	7.4*	5.4*	5.4*	5.0	4.1*	4.1*	3.7	3.4*	3.4*	2.9	2.8*	2.6	2.2	2.5*	2.1	1.7
0 m	Blade		7.7*	7.7*	7.6	5.4*	5.4*	5.0	4.2*	4.2*	3.6	3.4*	3.3	2.8	2.9*	2.5	2.1	2.4*	2.0	1.7
-1 m	Blade		7.7*	7.7*	7.4	5.4*	5.4*	4.7	4.2*	4.1	3.5	3.4*	3.2	2.7	2.9*	2.5	2.1			
-2 m	Blade		7.9*	7.9*	7.1	5.5*	5.5*	4.7	4.3*	4.1	3.4	3.5*	3.1	2.6	2.8*	2.4	2.0			
-3 m	Blade		8.1*	8.1*	7.2	5.7*	5.6	4.6	4.4*	4.0	3.3	3.3*	3.0	2.5						
-4 m	Blade		7.9*	7.9*	7.3	5.3*	5.3*	4.6	3.7*	3.7*	3.3									

Lift capacities in tons (T) at the articulated jib end, without bucket tipping cylinder, without tool. Values on level ground, locked pendulum axle, and pressure switched on. Values laterally to the undercarriage apply throughout 360° rotatable. The values Laterally 1) apply supported. The values longitudinally to the undercarriage apply supported across the rigid axle as well as unsupported across the steering axle. The indicated load values are stated according to ISO 10567, imply a stability of 25% and are calculated at 87% of the maximum hydraulic lifting capacity. An asterisk (\*) marks the values that are limited by hydraulic lifting capacity.





1919

**FOUNDATION**

Hinrich Weyhausen founds the company and initially produces agricultural equipment at the Delmenhorst location.

1945

**THE FIRST PATENT**

The first patent for an ATLAS attachment crane is granted.

1950

**FIRST FULLY HYDRAULIC EXCAVATOR**

With the first fully hydraulically operated ATLAS excavator, the success story for an entire industry begins.

1956

**ATLAS VECHTA**

Start-up of the ATLAS factory at Vechta.

1960

**ATLAS GANDERKESEE**

Start-up of the ATLAS factory at Ganderkesee.

1965

**RAIL-ROAD EXCAVATOR**

The world's first ATLAS rail-road excavator lays the foundation for a leading position in this market.

1980

**ATLAS UK**

Start-up of the Bradford, England location for production of ATLAS Cranes. Bradford, England.



1986

**ATLAS WHEELED EXCAVATOR 1304**

Market launch of the best-selling ATLAS excavator model yet.

2001

**CHANGE OF MANAGEMENT**

ATLAS is taken over by the American Terex Corporation.

2010

**ATLAS MASCHINEN GMBH**

The entrepreneur Fil Filipov acquires ATLAS and re-establishes the company as an independent business under the name of "ATLAS Maschinen GmbH".

2012

**SPARE PARTS GMBH**

Foundation of ATLAS Spare Parts GmbH – in order to improve the efficiency of spare parts supply.

2014

**NEW MANAGING DIRECTOR**

ATLAS expands its product portfolio by tunnel excavators. At the same time, Brahim Stitou is appointed as managing director with sole power of representation of ATLAS Maschinen GmbH.

2015

**INNOVATION 3**

ATLAS delivers the first electric excavator with many more to follow.

The newly founded ATLAS Group Services GmbH now provides all training courses, which take place in the in-house training center.

The name of the company is changed from ATLAS Maschinen GmbH to ATLAS GmbH.

2017

**MINI- AND MIDI-EXCAVATORS**

ATLAS expands its product portfolio by mini- and midi-excavators.

2019

**100-YEAR ANNIVERSARY**

ATLAS proudly looks back on a 100-year history and duly celebrates the centennial.

2020

**READY FOR THE FUTURE**

ATLAS presents the first battery-powered excavator. The 200 MH accu is used in recycling for Stadtreinigung Hamburg.

Effective immediately, ATLAS machines are equipped with a stage V exhaust after-treatment system.

ATLAS manufactures driver's cabs in-house.

2023

**A LOOK AHEAD INTO THE FUTURE**

ATLAS modernizes its branding, revises the type designations ZW, MW, wheeled, cranes, and enhances its profile to be well prepared for the future.

**INNOVATIVE.  
PASSIONATE.  
PIONEERING.  
SINCE 1919.**

# OUR STRONG DEALER NETWORK.

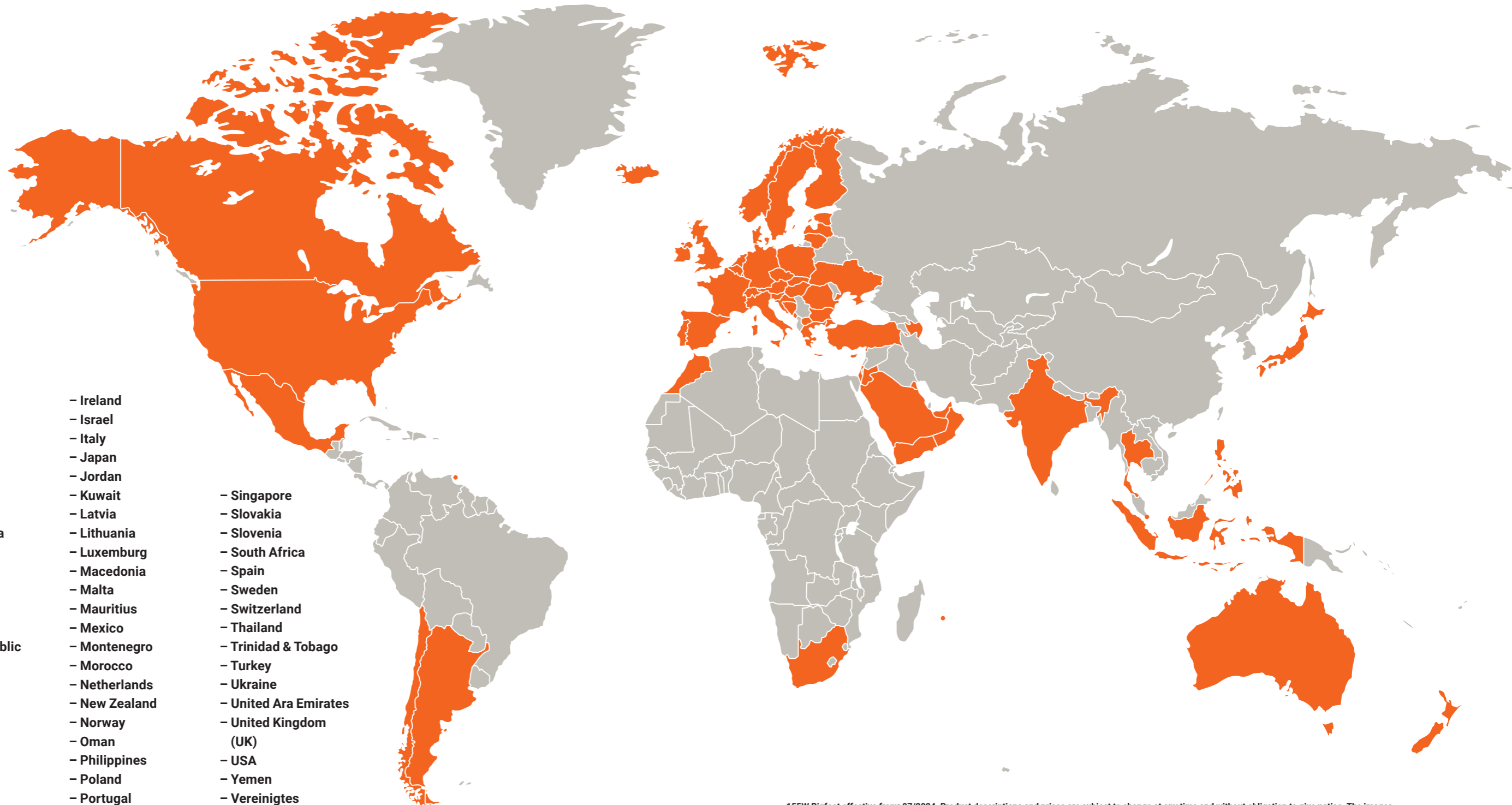

- Argentina
- Australia
- Austria
- Azerbaijan
- Bahrain
- Belgium
- Bosnia and Herzegovina
- Bulgaria
- Canada
- Chile
- Croatia
- Cyprus
- Czech Republic
- Denmark
- Estonia
- Finland
- France
- Germany
- Greece
- Hungary
- Iceland
- India
- Indonesia
- Ireland
- Israel
- Italy
- Japan
- Jordan
- Kuwait
- Latvia
- Lithuania
- Luxemburg
- Macedonia
- Malta
- Mauritius
- Mexico
- Montenegro
- Morocco
- Netherlands
- New Zealand
- Norway
- Oman
- Philippines
- Poland
- Portugal
- Rumania
- Saudi Arabia
- Singapore
- Slovakia
- Slovenia
- South Africa
- Spain
- Sweden
- Switzerland
- Thailand
- Trinidad & Tobago
- Turkey
- Ukraine
- United Ara Emirates
- United Kingdom (UK)
- USA
- Yemen
- Vereinigtes Königreich (UK)
- Zypern

155W Bigfoot effective from: 07/2024. Product descriptions and prices are subject to change at any time and without obligation to give notice. The images and/or drawings contained in this document are for illustrative purposes only and may differ from the standard version. For instructions for proper use, please refer to the corresponding operation manual. Failing to observe the operating manual when using our products or other negligent behavior may result in serious personal injury or death. The only warranty applicable to this product is the corresponding standard written warranty. ATLAS does not provide any warranty beyond this, neither explicitly nor implicitly. The designations of the listed products and services may be trademarks, service marks or trade names of ATLAS GmbH and / or their affiliates. All rights reserved. "ATLAS" is a registered trademark of Atlas GmbH.

Copyright © 2024 ATLAS GmbH.

**GANDERKESEE FACTORY**

Atlas GmbH  
Atlasstrasse 6  
27777 Ganderkesee, Germany  
T: +49 (0) 4222 954 0  
F: +49 (0) 4222 954 220  
info@atlasgmbh.com  
www.atlasgmbh.com

**VECHTA FACTORY**

Atlas GmbH  
Theodor-Heuss-Str. 3  
49377 Vechta, Germany  
T: +49 (0) 4441 954 0  
F: +49 (0) 4441 954 299  
info@atlasgmbh.com  
www.atlasgmbh.com

**DELMENHORST FACTORY**

Atlas GmbH  
Stedinger Strasse 324  
27751 Delmenhorst, Germany  
T: +49 (0) 4221 49 10  
F: +49(0)4221491443  
info@atlasgmbh.com  
www.atlasgmbh.com

**ENGLAND LOCATION**

Atlas Cranes UK Ltd.  
National Sales & Service Facility  
Wharfedale Road,  
Euroway Trading Est.  
Bradford, England BD4 6SL  
United Kingdom  
T: +44 1274900900  
F: +44 274653785  
atlasuk@atlasgmbh.com  
www.atlas-cranes.co.uk