



ATLAS SINCE 1919

ATLAS ACCESSORY EQUIPMENT for excavators

ACCESSORY EQUIPMENT



PRODUCT RANGE



MOBILE EXCAVATORS

ATLAS mobile excavators are the all-purpose excavators for road construction and underground engineering work. They are enormously strong, solid and mobile and can be operated effectively in virtually all kinds of conditions.

- Excellent stability for maximum performance
- Optimal centre of gravity and ideal weight distribution
- Precise digger control with a sensitive hydraulic system
- Streamlined for trench work, strong design and construction



RAIL-ROAD EXCAVATORS

The ATLAS Rail-Road Excavators are adaptable and flexible: the new computer-aided CARSY system ensures optimal contact pressure with the rails. They can be used for an array of applications, from cutting works to dismantling and upgrading the railway track.

- More than 30 years manufacturing experience
- Optimal stability - Allows easy railing / de-railing and convenient handling for operators
- Versatility
- Mechanical Expertise
- Security
 - Automatic self-diagnosis
 - Emergency de-railing is permanently available and double protected on rail guide wheels
 - Fast cycle times
 - Optimised handling

MOBILBAGGER

Die ATLAS Mobilbagger sind die Universalbagger beim Straßen- und Tiefbau. Ihre enorme Kraft, Standfestigkeit und Mobilität ermöglichen ein effektives Arbeiten unter nahezu allen Einsatzbedingungen.

- Maximale Leistung dank exzellenter Stabilität
- Optimaler Schwerpunkt und ideale Gewichtsverteilung
- Präzise Baggersteuerung über feinfühliges Hydraulik
- Optimiertes Design für Grabarbeiten, robuste Konstruktion, Bedienerfreundlichkeit

ZWEIWEGBAGGER

Die ATLAS Zweiwegebagger sind anpassungsfähig und flexibel: Das computergestützte CARSY System gewährleistet optimalen Anpressdruck auf die Schienen. Die Bagger sind vielseitig einsetzbar, von Böschungsarbeiten bis hin zu Modernisierung von Gleisanlagen.

- Mehr als 30 Jahre Erfahrung
- Optimale Stabilität
 - Ermöglicht leichtes Auf- und Abgleisen
 - Bequeme Handhabung für den Bediener
- Vielseitigkeit
- Know-how in der Konstruktion
- Sicherheit
 - Automatische Selbstdiagnose
 - Notausgleisung immer gewährleistet und doppelt abgesichert
 - Schnelle Zyklen
 - Hohe Bedienerfreundlichkeit

PRODUCT RANGE



MATERIAL HANDLING MACHINES

ATLAS material handlers include mobile industrial machines and industrial tracked machines, which work on applications such as scrap, wood, bulky goods, special recycling, port applications and vacuum operations.

- Fast cycle times
- Optimised handling
- Mechanical expertise
- 20 years manufacturing experience
- Reliability
- Extended life span
- Versatility
- Range of diverse equipment to meet customer expectations



CRAWLER EXCAVATORS

Maximum digging performance, large loads and superior tear-out and break-away forces thanks to excellent kinematics. Maximum power with Cummins high-performance engines. Fast, sensitive working cycles with a newly-developed Rexroth hydraulic system.

- Powerful
- Fast operating cycles
- Easy to operate
- Low fuel consumption
- Easy maintenance
- Excellent visibility

UMSCHLAGMASCHINEN

ATLAS Lademaschinen sind mobile Umschlagmaschinen und Umschlagmaschinen mit Raupenfahrwerk für den industriellen Einsatz bei z.B. Schrott, Holz, sperrigen Gütern und Recycling, in Häfen und bei Spezialarbeiten.

- Know-how in der Konstruktion
- 20 Jahre Erfahrung
- Schnelle Zyklen
- Hohe Bedienfreundlichkeit
- Zuverlässigkeit
- Lange Lebensdauer
- Vielseitigkeit
- Große Auswahl an Zusatzausrüstungen

RAUPENBAGGER

Optimale Grableistung, hohe Traglasten sowie überlegene Reiß- und Losbrechkkräfte durch sehr gute Kinematik. Maximale Leistung durch Cummins Hochleistungsmotoren. Schnelle und feinfühligere Arbeitsspiele durch neuentwickeltes Rexroth-Hydrauliksystem.

- Leistungsstark
- Schnellste Arbeitszyklen
- Hohe Bedienfreundlichkeit
- Niedriger Kraftstoffverbrauch
- Perfekte Wartungsfreundlichkeit
- Optimale Rundumsicht

Page	Content
5	Quick change devices (QCD)
6	Quick change devices for changing the grab with a grab - as well as Oil Quick and Verachtert
7	Articulation pieces - quick change, grab adaptations - Verachtert - Lehnhoff - Oil Quick
8	Articulation pieces - permanent installation
9	Grab rotation gear
10	Hydraulic packages - Grab extensions
11	Clamshell bucket for E4.2
12	Clamshell bucket for E8.2
13	Clamshell bucket for E11.2
14	Clamshell bucket for E12
15	Clamshell bucket for E32
16	Clamshell bucket for E31.2
17	Clamshell bucket for E332
18	Rail tongs for E332
19	Clamshell bucket for E332
20	Clamshell bucket for E2.62
21	Clamshell bucket for E732-2 and E832-2
22	Log grab for E32
23	Log grab for E732 and E832-2
24	Grapple and grab for round shafts for E32 - Beet grab for E332
25	Demolition and sorting grab for E332, swinging freely and with a screw adaptor
26	Multi-jaw grab, 5 arms, for E11.32 and E732
27	Multi-jaw grab, 4 arms, for E732
28	Multi-jaw grab 5 arm für E732
29	Multi-jaw grab, 4 and 5 arms, for E832-2
30	Connecting part for hydraulic hammer - connecting plate for welding - adaptors
31	Product line of dippers and buckets
32	Attachments for a dipper: AB 1004, 1104, 1204
33	Bucket: standard design with ATLAS B1 tooth system or a non-serrated blade
34	Quick change connectors from other manufacturers suitable for backhoe bucket - additional prices
35	Rock bucket - HD-design with wear plates and ATLAS B2 tooth system
36	Rock bucket - HD-design with wear plates and ATLAS B3 and B4 tooth system
36	Rock bucket - HD-design with wear plates suitable for 210 - 260LC with CAT tooth system
37	Drainage bucket; trench lining bucket, dipper for loamy soil
38	Trench digger: rear blade, fixed
39	Trench digger: rear blade, swivel movement available
40	Trench digger, bucket shape with rear blade and fixed to the ground or swivelling
41	Multi-purpose bucket, bucket shape without rear blade, fixed or swivelling
42	Quick change connectors from other manufacturers suitable for trench digger - additional prices
43	SWINGOTILT
44	Ripper tooth, heavy duty fork, load hook, capable / incapable of rotation
45	Pallet forks , original load-lifting magnets MOZELT
46	Michaelis mowing bucket

Quick change devices (QCD)

suitable for articulated jibs with a dipper-tipping cylinder and a reverse gear for changing the dipper (bucket) with a dipper (bucket), the bucket with a grab or the grab with another grab

Material No.	Type designation	Arm width (mm)	Bolt Ø	with ... T load hook	Recommended excavator size	Weight (kg)
4108416	T4.20	105	35	without	1 - 2 t	20
3198025	T8.20	150	40	without	3 - 5 t	29
2521300	T11.20	168	50	without	6 - 11 t	35
4545448	T620V	268	60	10 - UKN8	9 - 23 t	115
6186126	T620VH-RH400	268	60	10 t	13 - 23 t	205
6186127	T620VH-RH440RAIL	268	60	10 t	18 - 23 t	205
T620VH-RH400 and T620VH-RH440Rail are fully hydraulic Riedlberger quick-change devices						
6141104	T620SMP2-STD	268	60	10 - UKN8	10 - 23 t	90
6139674	T620SMP2-EURO	268	60	10 - UKN8	10 - 23 t	98
4538358	T620H	268	60	10 - UKN8	10 - 23 t	130
with hydraulic latching; a hydraulic attachment kit for excavators is required (in conjunction with a SW (quick-coupler) joint plate and a SW (quick-coupler) load hook, a wedge with a wrench, material no. 5411278 is required)						
5445449	T63.20-270	268	60	10	10 - 23 t	181
suitable for work attachments with connection T63.20						
6112694	T63.20H-270	268	60	10	10 - 23 t	210
with hydraulic latching; a hydraulic attachment kit for excavators is required (in conjunction with a SW (quick-coupler) joint plate and a SW (quick-coupler) load hook, a wedge with a wrench, material no. 5411278 is required)						
4568445	T63.20	300	80	10	17 - 26 t	188
4568456	T63.20H	300	80	10	17 - 26 t	215
with hydraulic latching; a hydraulic attachment kit for excavators is required (in conjunction with a SW (quick-coupler) joint plate and a SW (quick-coupler) load hook, a wedge with a wrench, material no. 5411278 is required)						
6127030	T63.20-311	311	80	10	17 - 26 t	182
suitable for work attachments with connection T63.20						
6127051	T63.20H-311	311	80	10	17 - 26 t	215
with hydraulic latching; a hydraulic attachment kit for excavators is required (in conjunction with a SW (quick-coupler) joint plate and a SW (quick-coupler) load hook, a wedge with a wrench, material no. 5411278 is required)						
4551037	T620-300	300	80	10	17 - 26 t	105
passend für Werkzeuge mit Anschluss T620						
5448022	T620H-300	300	80	10	17 - 26 t	127
with hydraulic latching; a hydraulic attachment kit for excavators is required (in conjunction with a SW (quick-coupler) joint plate and a SW (quick-coupler) load hook, a wedge with a wrench, material no. 5411278 is required)						
6116761	T620-311	311	80	10	17 - 26 t	130
suitable for work attachments with connection T620						
6104952	T620H-311	311	80	10	17 - 26 t	155
with hydraulic latching; a hydraulic attachment kit for excavators is required (in conjunction with a SW (quick-coupler) joint plate and a SW (quick-coupler) load hook, a wedge with a wrench, material no. 5411278 is required)						
4541320	T722	forked	80	10	22 - 35 t	253
4541400	T722 H	forked	80	10	22 - 35 t	275
with hydraulic latching; a hydraulic attachment kit for excavators is required (in conjunction with a SW (quick-coupler) joint plate and a SW (quick-coupler) load hook, a wedge with a wrench, material no. 5411278 is required)						



We reserve the right to make technical changes in the course of further development! **ATLAS GmbH**, 27777 Ganderkesee

ATLAS GmbH - Atlas Str. 6 -27777 Ganderkesee

Tel.: +49 (0) 4222 954-0 -Fax : +49 (0) 4222 954343

Offer list: Attachments for hydraulic excavators

Quick change devices for changing the grab with a grab

Material No.	Type designation	Arm width (mm)	Bolt Ø	with ... T load hook	Recommended excavator size	Weight (kg)
1491130	T610 Bolts, a wedge and a wrench, bolts with centring sleeves for the holder of the quick change joint plate, load hook, etc.	268	60		12 - 23 t	30
4568467	T63.10 Bolts, a wedge and a wrench, bolts with centring sleeves for the holder of the quick change joint plate, load hook, etc.	300	80		17 - 26 t	32
5411267	T713 Bolts and a wrench, bolts with centring sleeves for the holder of the quick change joint plate, load hook, etc.	345	80		26 - 50 t	24
5411278	Wedge with a wrench					12

Quick-coupler system Lehnhoff - Price upon request
Quick-coupler systems Lehnhoff are delivered red painted!

T610



Oil Quick Original quick coupler - with an attachment (for retrofitting)						
6150119	SWE-OQ65-SH-270-60	268	60	10	14 - 22 t	200
6157484	SWE-OQ65-SH-300-80	300	80	10	14 - 22 t	200
6158079	SWE-OQ65-SH-311-80	311	80	10	14 - 22 t	200
6148988	SWE-OQ70/55-SH-270-60	268	60	10	18 - 32 t	250
6150150	SWE-OQ70/55-SH-300-80	300	80	10	18 - 32 t	250
6096815	SWE-OQ70/55-SH-311-80	311	80	10	18 - 32 t	250

Oil Quick Original quick coupler - mounted to a new excavator by the manufacturer						
6160392	SWE-OQ65-SH-270-60	268	60	10	14 - 22 t	200
6161197	SWE-OQ65-SH-300-80	300	80	10 (loose)	14 - 22 t	200
6161198	SWE-OQ65-SH-311-80	311	80	10	14 - 22 t	200
6161231	SWE-OQ70/55-SH-270-60	268	60	10	18 - 32 t	250
6161234	SWE-OQ70/55-SH-300-80	300	80	10 (loose)	18 - 32 t	250
6161235	SWE-OQ70/55-SH-311-80	311	80	10	18 - 32 t	250

Quick coupler Verachttert						
6178646	SWE CW.3.SPD.L 270-60 with spindle suitable for CW20-40 550 mm wide	268	60	7,5	13 - 21 t	220
6166385	SWE HCW.3 270-60 hydraulic suitable for CW20-40 550 mm wide	268	60	7,5	13 - 21 t	220



SWE HCW4 300-80LH
6181712



Hydraulic quick change device
Oil Quick Original

We reserve the right to make technical changes in the course of further development! ATLAS GmbH, 27777 Ganderkesee

ATLAS GmbH - Atlas Str. 6 -27777 Ganderkesee

Tel.: +49 (0) 4222 954-0 -Fax : +49 (0) 4222 954343

Offer list: Attachments for hydraulic excavators

Articulation pieces - ATLAS - quick change, connection between the articulated jib end and the grab rotation gear

Material No.	Type designation	Suitable for SWE (quick change devices)		Suitable for	Recommended excavator size	Weight (kg)
3132265	T11.40	T11.20	without wedge	E11.2, E11.32	6 - 11 t	40
6011101	T630	T620V , T620 H, T610	without wedge	E12, E31.2, E32, E332	12 - 23 t	62
3105911	T630 S GER.PLATTE	T620V , T620 H, T610	without wedge	for welding	12 - 23 t	44
6141102	T630SMP2-STD	T620SMP2-STD	with wedge	E12, E31.2,E32,E332	12 - 23 t	82
6139673	T630SMP2-EURO	T620SMP2-EURO	with wedge	E12, E31.2,E32,E332	12 - 23 t	90
4568489	T63.31	T63.20 , T63.20 H	without wedge	E12, E31.2, E32, E332	17 - 26 t	90
4568003	T63.34	T63.20 , T63.20 H	without wedge	E2.62, E713, E732 E732-2	17 - 26 t	105
4578174	T730	T620V , T620 H	without wedge	E2.62, E713, E732 E732-2	17 - 26 t	71
4528618	T731	T722 , T722H	with wedge	E2.62, E713, E732 E732-2	17 - 35 t	118
4516772	T733	T713	with wedge	E12, E31.2, E32, E332	17 - 35 t	120
3510876	T734	T713	with wedge	E2.62, E713, E732 E732-2	26 - 50 t	130
6163524	T832-660L	T713	with wedge	E832-2	26 - 50 t	150

Grab adaptations Schaeff

6101513	GA-SWE-TC16-E4.2			E4.2	1 - 2 t	20
---------	------------------	--	--	------	---------	----

Grab adaptations Verachttert

6119390	GA-CW20-40BR-E32	CW20 - 40br	wide version	E12, E32, E332	10 - 19 t	130
6160617	GA-CW20-40BR-E2.62	CW20 - 40br	wide version	E2.62, E713, E732 E732-2	26 - 50 t	118

Grab adaptations Lehnhoff

6128022	GA-MS01-E4.2	MS01 / HS01		E4.2	1 - 2 t	21
6128191	GA-MS03-E8.2	MS03 / HS03		E8.2	3 - 5 t	35
6068804	GA-MS08-E11.2	MS08 / HS08		E8.2	6 - 11 t	65
6142003	GA-MS08-E12	MS08 / HS08		E12, E32, E332, E31.2	5 - 12 t	60
6132361	GA-MS10-E32	MS10 / HS10		E12, E32, E332, E31.2	10 - 19 t	170
6132350	GA-MS21-E32	MS21 / HS21		E12, E32, E332, E31.2	19 - 26 t	205
6135913	GA-MS21/25-E2.62	MS21 / HS21		E2.62, E732, E732-2	19 - 35 t	228

Grab adaptations Oilquick (HP not necessary)

6140596	GA-OQ65-T31	OQ65	T31 required	E12, E32, E332, E31.2	12 - 23 t	165
6140951	GA-OQ70-55-T31	OQ70-55	T31 required	E12, E32, E332, E31.2	12 - 23 t	150
6152199	GA-OQ70-55-T64	OQ70-55	T64 erforderl.	E2.62, E732, E732-2	19 - 35 t	155

Additional quick couplers (SW) - grab adaptations for Lehnhoff, Verachttert and Oilquick - can be supplied upon request!



We reserve the right to make technical changes in the course of further development! ATLAS GmbH, 27777 Ganderkesee

ATLAS GmbH - Atlas Str. 6 -27777 Ganderkesee

Tel.: +49 (0) 4222 954-0 -Fax : +49 (0) 4222 954343

Offer list: Attachments for hydraulic excavators

Articulation pieces - permanent installation, connection between the articulated jib end and a grab rotation gear

Material No.	Type designation	Altitude (mm)	Arm width (mm)	Bolt Ø	Suitable for	Recommended excavator size	Weight (kg)
3523462	T4.2	180	110	35	E4.2	1 - 2 t	4
3135600	T8.2	280	150	40	E8.2	3 - 5 t	9
2593748	T11.4	240	168	50	E11.2, E11.32	6 - 11 t	15
3168530	T21	320	268	60	E11.2, E11.32	9 - 22 t	30
1586714	T31	300	268	60	E12, E31.2, E32, E332	12 - 23 t	25
1572810	T35	250 / 350 re-arrangeable	268	60	E12, E31.2, E32, E332 mainly for grabs with low altitude	12 - 23 t	41
1572832	T36	490	268	60	E12, E31.2, E32, E332	12 - 23 t	43
Altitude: 490 mm long, mainly for steeply positioned jibs and telescopic articulated jibs							
2228779	T64	450	268	60	E2.62, E713, E732, E732-2	17 - 26 t	60
1572854	T2.61	450	290	60	E2.62, E713, E732, E732-2	17 - 26 t	65
1572876	T2.62	380	290	60	E12, E31.2, E32, E332	17 - 23 t	41
5401743	T63.01	440	300	80	E12, E31.2, E32, E332	17 - 23 t	57
4568490	T63.04	400	300	80	E2.62, E713, E732, E732-2	17 - 26 t	54
1572912	T71	480	gegabelt	80	E2.62, E713, E732 E732-2	17 - 35 t	60
1572898	T72	380	345	80	E2.62, E713, E732 E732-2	17 - 35 t	55
Industrial articulated jibs							
2214319	T74	420	345	80	E32	17 - 35 t	54
Industrial articulated jibs							
6104916	T72-311	450	311	80	E2.62, E713, E732 E732-2	17 - 35 t	81
3189057	T81	480	forked	80	E832-2	26 - 50 t	105
6162290	T82-630L	630	345	80	E832-2	26 - 50 t	150
Industrial articulated jibs							



T11.4



T31



T72



T82-630L

We reserve the right to make technical changes in the course of further development! ATLAS GmbH, 27777 Ganderkesee

ATLAS GmbH - Atlas Str. 6 -27777 Ganderkesee

Tel.: +49 (0) 4222 954-0 -Fax : +49 (0) 4222 954343

Offer list: Attachments for hydraulic excavators

Grab rotation gear, hydraulically advancing by an oil engine, capable of rotation

Material No.	Type designation		Recommended excavator size	Weight (kg)
6135920	E4.2	without a grab cylinder	1 - 2 t	19
3175200	E8.2	with a grab cylinder	3 - 5 t	90
4512507	E11.2	with a grab cylinder	6 - 11 t	140
4513042	E11.32	without a grab cylinder	6 - 11 t	65
6030688	E12	with a grab cylinder	10 - 15 t	200
6030684	E31.2	with a grab cylinder	12 - 23 t	215
6014722	E32	with a grab cylinder	12 - 23 t	230
6133809	E32SV	with a grab cylinder and safety valve	12 - 23 t	230
6015121	E332	without a grab cylinder	12 - 23 t	90
4514190	E2.62	with a grab cylinder	17 - 35 t	380
3593999	E713	with a grab cylinder, for a deep-grab gear suitable for all kinds of E32 grabs, E35 - E310.5 E714 is required as extension	17 - 35 t	320
4515511	E732	without a grab cylinder	17 - 35 t	150
5453052	E732-2	without a grab cylinder, with 2 rotary motors	17 - 35 t	170
6077949	E832-2	without a grab cylinder, with 2 rotary motors	25 - 50 t	200



We reserve the right to make technical changes in the course of further development! **ATLAS GmbH**, 27777 Ganderkesee

ATLAS GmbH - Atlas Str. 6 -27777 Ganderkesee

Tel.: +49 (0) 4222 954-0 -Fax : +49 (0) 4222 954343

Offer list: Attachments for hydraulic excavators

Hydraulic package (compl. SL- connection, articulated jib - grab rotation gear with SV-couplings)

Material No.	Type designation	Grab rotation gear	Articulation piece SW (quick coupler) articulation piece	ATLAS excavator	Arm width (mm)	SL - size SL - size
3173628	HP-E8.2-T8.4	E8.2	T8.2	804	150	SL 8 x 1600 SL 10 x 1600
3168392	HP-E11.2-T11.4	E11.2 , E11.32	T11.4 T21	1004 1104, 1204	168 268	SL 10 x 1350 SL 16 x 1500
5440126	HP-E11.2-11.40	E11.2 , E11.32	T11.40	1004	168	SL 10 x 1350 SL 16 x 1500
5416137	HP-E12-T31	E12	T31	1104/1204	268	SL 10 x 1600 SL 16 x 1600
5412393	HP-E12-T630	E12	T630	1104/1204	268	SL 10 x 1600 SL 16 x 1700
5441514	HP-E32-T31	E32, E 332, E31.2	T31, T35	12-1605,1604 /1705 130W-170W	268	SL 10 x 1600 SL 20 x 1700
5400742	HP-E32-T630	E32, E332, E31.2	T630	12-1605,1604 /1705 130W-170W	268	SL 10 x 1600 SL 20 x 1800
5404008	HP-E32-T63.01	E32, E332	T63.01, T63.31	1605,1705,1805,1905 190W, 220W	300	SL 10 x 2000 SL 20 x 1800
5404031	HP-E2.62-T64	E2.62,E732,E732-2	T64, T730	12-1605,1604/1705 130-170W 1705 (T620-300) 190W, 220W (T620-300)	268 (300)	SL10 x 1600 SL 20 x 2000
5401709	HP-E2.62-T63.04	E2.62,E732,E732-2	T63.04, T63.34	2005,2205 190W, 220W	300	SL10 x 1800 SL 20 x 2000
5404019	HP-E2.62-T71	E2.62, E72 E732, E732-2, E832-2	T71, T731, T81, T831, GA-MS10	1704 - 1804	forked	SL10 x 2300 SL 20 x 2300
5412439	HP-E2.62-T72	E2.62, E72 E732, E732-2, E832-2	T72, T734	1704,1804 Indust. and telescopic 270MH, 350MH 1304-1705	345	SL10 x 1600 SL 20 x 1600
3178645	HP-E732-T64	E32, E 332, E 31.2 E2.62,E732,E732-2	T36, T630 T64 , T730	1705 Indust. and telescopic 180MH,200MH	268	SL10 x 1800 SL 20 x 1700
6079002	HP-E732-T64-MI	E32, E332, E31.2 E2.62,E732,E732-2	T630, T2.61, T2.62	1604Mi, 230MH AB1622	268 290	SL 10 x 1800 SL 20 x 2000
5412440	HP-E832-2-T832-MI	E832-2	T832, T82	1804MI,350MH Ind.uTele	345	SL 10 x 1800 SL 20 x 1800
6041142	HP-E832-2-T832	E2.62, E732, E732-2, E832-2	T72, T734, T82, T832	5205, 520MH	345	SL 10 x 2300 SL 20 x 2300

Grab extensions

Material No.	Type designation	Length mm		Suitable for	Weight kg
0727633	E34	1000	with 4 hoses	E32	65
0742267	E34.1	1 500	with 4 hoses	E32	90
0732572	E34.2	2 000	with 4 hoses	E32	115
6151206 6151207	In order to connect the two extensions E34-E34.2 you need extra 1x for each : Connecting tube short Connecting tube long				0,5 0,5
0728598	E74	1 000	with 2 hoses	E2.62	130
0742278	E74.2	2 000	with 2 hoses	E2.62	200
3594014	E714	2 000	with 2 hoses	E713	110



Verbindungsrohr
lang 6151207
kurz 6151206



2x E714

We reserve the right to make technical changes in the course of further development! ATLAS GmbH, 27777 Ganderkesee

ATLAS GmbH - Atlas Str. 6 -27777 Ganderkesee

Tel.: +49 (0) 4222 954-0 -Fax : +49 (0) 4222 954343

Offer list: Attachments for hydraulic excavators

Clamshell grab with a horizontal grab cylinder Grab rotation gear E 4.2 is required

Material No.	Type designation	Width	Litres		Recommended excavator size	Weight kg
3511731	E4.5	270	40	with an ejector 3 screw teeth	1 - 2 t	80
3511800	E4.6	350	50	with an ejector 4 screw teeth	1 - 2 t	90

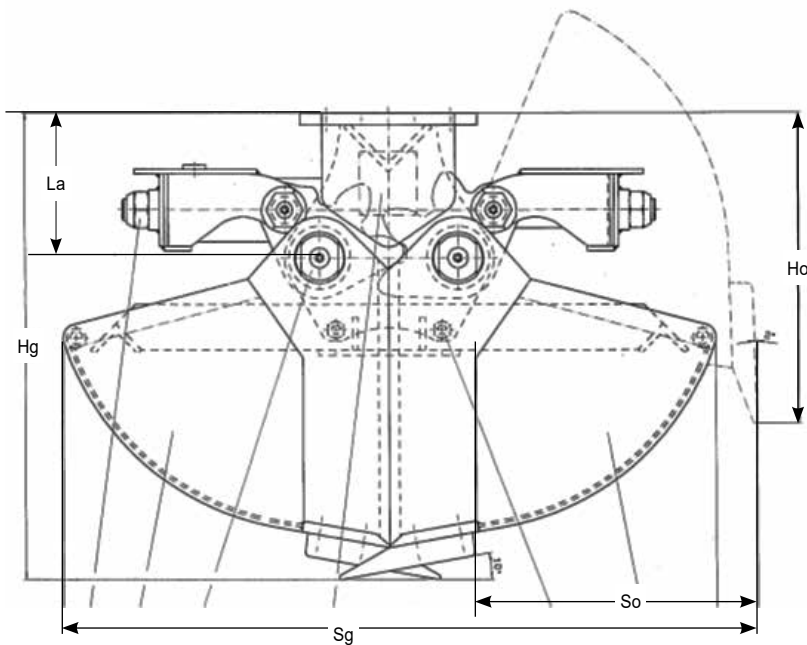

Type designation	Material No.	Hg	Ho	La	Sg	So
E4.5	3511731	515	344	160	730	820
E4.6	3511800	515	344	160	730	820
Altitude of rotation gear E4.2 incl. T4.2 = 320 mm						
Operating pressure: max 160 bar						



ATLAS GmbH - Atlas Str. 6 -27777 Ganderkesee

Tel.: +49 (0) 4222 954-0 -Fax : +49 (0) 4222 954343

Offer list: Attachmentsfor hydraulic excavators

Clamshell bucket without a grab cylinder Grab rotation gear E8.2 is required

Material no.	Type designation	Width	Litres		Recommended excavator size	Weight kg
3173844	E8.5	200	50	with an ejector 3 screw teeth	3 - 5 t	112
3173946	E8.6	270	70	with an ejector 3 screw teeth	3 - 5 t	120
3174027	E8.7	450	100	without an ejector 3 screw teeth	3 - 5 t	127
6102084	E8.7.5	450	100	with an ejector 3 screw teeth	3 - 5 t	130

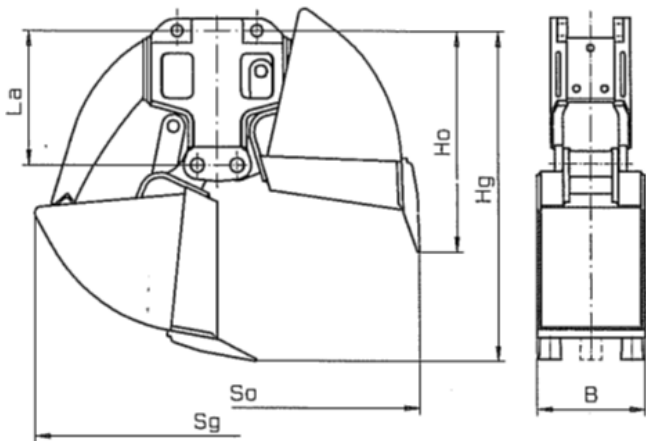

E8.5 - E8.7



Type designation	Material No	Hg	Ho	La	Sg	So
E8.5	3173844	815	545	331	910	1000
E8.6	3173946	815	545	331	910	1000
E8.7	3174027	815	545	331	910	1000
E8.7.5	6102084 as E8.7 but with an ejector					
Altitude of rotation gear E8.2 incl. T8.4 = 611 mm						
Operating pressure: max 200 bar						

ATLAS GmbH - Atlas Str. 6 -27777 Ganderkesee

Tel.: +49 (0) 4222 954-0 -Fax : +49 (0) 4222 954343

Offer list: Attachmentsfor hydraulic excavators

Clamshell bucket without a grab cylinder
Grab rotation gear E 11.2 is required

Material No.	Type designation	Width	Litres		Recommended excavator size	Weight kg
2553819	E11.5	300	110	with an ejector 3 screw teeth	6 - 11 t	240
2553886	E11.6	400	150	with an ejector 3 screw teeth	6 - 11 t	220
2553466	E11.7	600	220	without an ejector 5 screw teeth	6 - 11 t	258
2553740	E11.7.5	600	220	with an ejector 5 screw teeth	6 - 11 t	295
6035451	E11.8	800	450	without an ejector 7 screw teeth	6 - 11 t	390

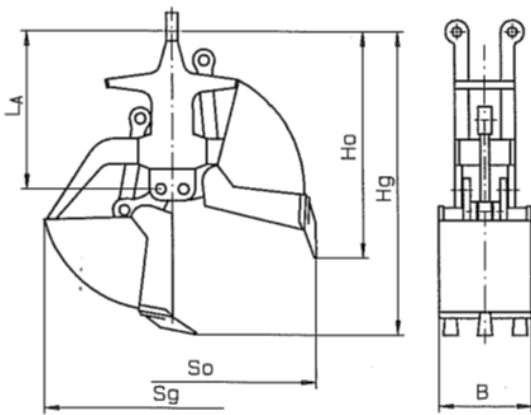

E11.5 - E11.8

Type designation	Material No.	Hg	Ho	La	Sg	So
E11.5	2553819	1300	930	675	1120	1300
E11.6	2553886	1300	930	675	1120	1300
E11.7	2553466	1300	930	675	1120	1300
E11.7.5	2553740 as E11.7 but with an ejector					
E11.8	6035451	1425	945	675	1378	1542
Altitude of rotation gear E11.2 incl. T11.4 = 630 mm						
Operating pressure: max 250 bar						

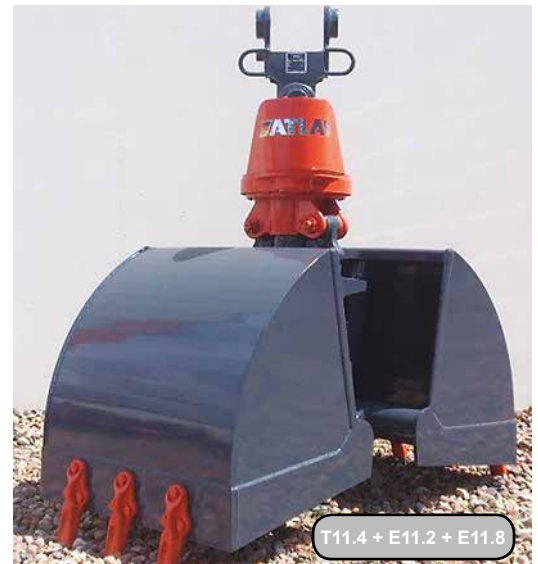

We reserve the right to make technical changes in the course of further development! **ATLAS GmbH**, 27777 Ganderkesee

ATLAS GmbH - Atlas Str. 6 -27777 Ganderkesee

Tel.: +49 (0) 4222 954-0 -Fax : +49 (0) 4222 954343

Offer list: Attachmentsfor hydraulic excavators

Clamshell bucket without a grab cylinder Grab rotation gear E 12 is required

Material No.	Type designation	Width	Litres		Recommended excavator size	Weight kg
1419201	E15	300	170	with an ejector 3 screw teeth	10 - 15 t	370
1419198	E16	400	210	with an ejector 3 screw teeth	10 - 15 t	390
1922609	E16 - 500	500	280	with an ejector 4 screw teeth	10 - 15 t	413
1419176	E17	600	300	without an ejector 5 screw teeth	10 - 15 t	390
1497590	E17.1	ejector for retrofitting from E17 to E17.5 including bolts			10 - 15 t	40
1419187	E17.5	600	300	with an ejector 5 screw teeth	10 - 15 t	410
1419165	E19	800	400	without an ejector 7 screw teeth	10 - 15 t	420

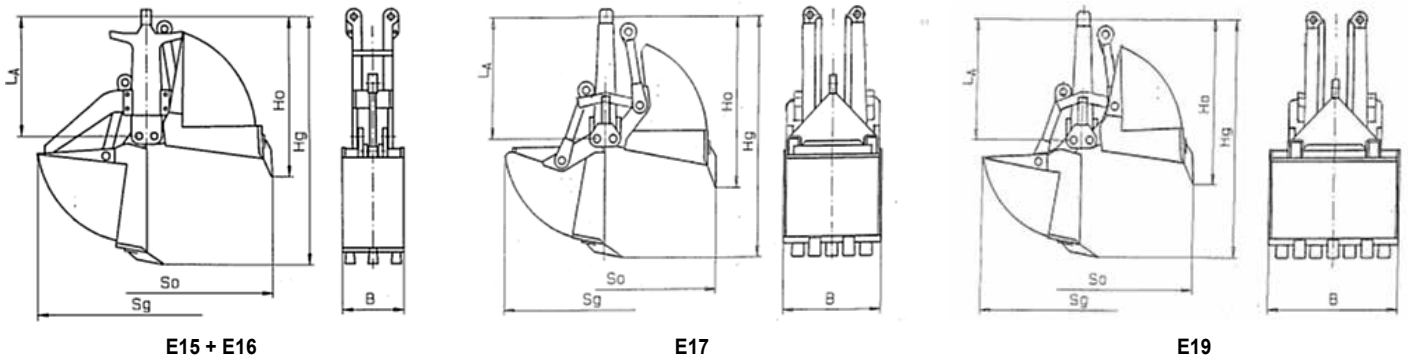

Type designation	Material no.	Hg	Ho	La	Sg	So
E15	1419201	1520	1025	745	1430	1620
E16	1419198	1520	1025	745	1430	1620
E16-500	1922609	1520	1025	745	1430	1620
E17	1419176	1375	985	700	1240	1420
E17.5	1419187 as E17 but with an ejector					
E19	1419165	1375	985	700	1240	1420
Altitude of rotation gear E12 incl. T31 = 827 mm						
Operating pressure: max 250 bar						



We reserve the right to make technical changes in the course of further development! ATLAS GmbH, 27777 Ganderkesee

ATLAS GmbH - Atlas Str. 6 -27777 Ganderkesee

Tel.: +49 (0) 4222 954-0 -Fax : +49 (0) 4222 954343

Offer list: Attachments for hydraulic excavators

Clamshell bucket without a grab cylinder Grab rotation gear E 32 is required

Material No.	Type designation	Width	Litres		Recommended excavator size	Weight kg
1517324	E35	300	170	with an ejector	12 - 23 t	470
1517222	E36	400	210	3 screw teeth, load hook 5 t with an ejector	12 - 23 t	500
3081296	E37	500	280	3 screw teeth, load hook 5 t with an ejector	12 - 23 t	530
1517131	E38	600	300	4 screw teeth, load hook 5 t without an ejector	12 - 23 t	500
1512534	E38.1	ejector for retrofitting from E38 to E38.5 4 bolts 0586530 are required.				68
1517120	E38.5	600	300	5 screw teeth, eylet for shackle 5 t with an ejector	12 - 23 t	580
1517415	E39	800	400	withoOut an ejector	12 - 23 t	580
1512545	E39.1	ejector for retrofitting from E39 to E39.5 4 bolts 0586530 are required.				78
1517404	E39.5	800	450	7 screw teeth, eylet for shackle 5 t with an ejector	12 - 23 t	670
3081309	E310	1000	560	without an ejector	12 - 23 t	660
2545400	E310.1	ejector for retrofitting from E310 to E310.5 4 bolts 0586530 are required.				90
2545364	E310.5	1000	560	9 screw teeth, eylet for shackle 5 t with an ejector	12 - 23 t	750
4685674	LASTH. 5TO	load hook 5 t for welding				5

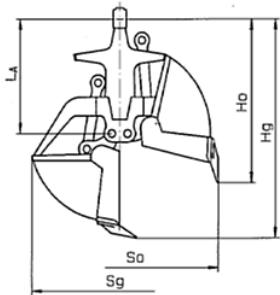

E35-E37



E32-E35

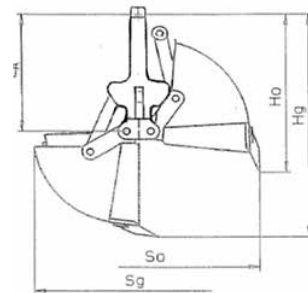

E38-E310

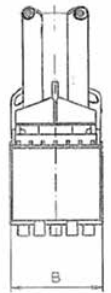

Type designation	Material No.	Hg	Ho	La	Sg	So	
E35	1517324	1615	1145	840	1465	1630	
E36	1517222	1615	1145	840	1465	1630	
E37	3081296	1615	1145	840	1465	1630	
E38	1517131	1520	1070	800	1390	1550	
E38.5	1517120	as E38 but with an ejector					
E39	1517415	1520	1070	800	1390	1550	
E39.5	1517404	as E39 but with an ejector					
E310	3081309	1520	1070	800	1390	1550	
E310.5	2545364	as E310 but with an ejector					
E310-700Lo.Zi.	6153154	1620	1070	800	1590	1750	
Altitude of rotation gear E32 incl. articulation piece T31 = 951 mm							
Operating pressure: max 300 bar							



LASTH. 5TO 4685674
welded on



T630 + E32 + E38

We reserve the right to make technical changes in the course of further development! ATLAS GmbH, 27777 Ganderkesee

ATLAS GmbH - Atlas Str. 6 -27777 Ganderkesee

Tel.: +49 (0) 4222 954-0 -Fax : +49 (0) 4222 954343

Offer list: Attachments for hydraulic excavators

Clamshell bucket without a grab cylinder Grab rotation gear E 32 is required

Material No.	Type designation	Width	Litres		Recommended excavator size	Weight kg	
4533659	E31.42	280	105	with an ejector 3 screw teeth	12 - 23 t	375	
4532409	E31.43	300	180	with an ejector 3 screw teeth	12 - 23 t	434	
4533580	E31.44	400	240	with an ejector 4 screw teeth	12 - 23 t	465	
3594649	E31.46	600	350	without an ejector 5 screw teeth	12 - 23 t	445	
3590634	E31.48	800	460	without an ejector 7 screw teeth	12 - 23 t	522	
6065939	E31.50	1 000	590	without an ejector 7 screw teeth	12 - 23 t	570	
4532227	E31.52	1 200	690	without an ejector 9 screw teeth	12 - 23 t	650	
4685674	LASTH. 5TO	load hook 5 t for welding					5

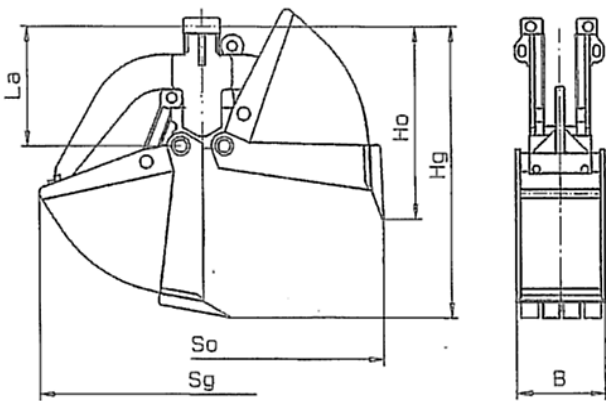

Type designation	Material No	Hg	Ho	La	Sg	So
E31.42	4533659	1145	835	532	1210	1350
E31.43	4532409	1295	855	532	1490	1650
E31.44	4533580	1295	855	532	1490	1650
E31.46	3594649	1265	830	532	1400	1550
E31.48	3590634	1265	830	532	1400	1550
E31.50	6065939	1265	830	532	1400	1550
E31.52	4532227	1265	830	532	1400 <td 1550	

Altitude of rotation gear E31.2 incl. T31 = 700 mm
Operating pressure: max 300 bar



We reserve the right to make technical changes in the course of further development! ATLAS GmbH, 27777 Ganderkesee

ATLAS GmbH - Atlas Str. 6 -27777 Ganderkesee

Tel.: +49 (0) 4222 954-0 -Fax : +49 (0) 4222 954343

Offer list: Attachments for hydraulic excavators

Clamshell bucket with two vertical grab cylinders and a rotary feed system, short design, grab rotation gear E 332 is required

Material No.	Type designation	Width	Litres		Recommended excavator size	Weight kg
4584605	E343	280	100	with an ejector 3 screw teeth	12 - 23 t	472
		Openings dimensions 1.350 above the teeth				
		Grab for gripping in between the sleepers				
6125592	E343-600	600	220	with an ejector 5 screw teeth	12 - 23 t	551
		Openings dimensions 1.350 above the teeth				
4685674	LASTH. 5TO	load hook 5 t for welding				5

Clamshell bucket with two horizontal grab cylinders and a rotary feed system, short design, grab rotation gear E 332 is required

Material No.	Type designation	Width	Litres		Recommended excavator size	Weight kg
1420942	E344	600	350	without an ejector 5 screw teeth	12 - 23 t	490
1420953	E345	700	400	without an ejector 5 screw teeth	12 - 23 t	585
1420964	E346	800	450	without an ejector 7 screw teeth	12 - 23 t	610
2580298	E348	1 000	560	without an ejector 7 screw teeth	12 - 23 t	640
4685674	LASTH. 5TO	load hook 5 t for welding				5

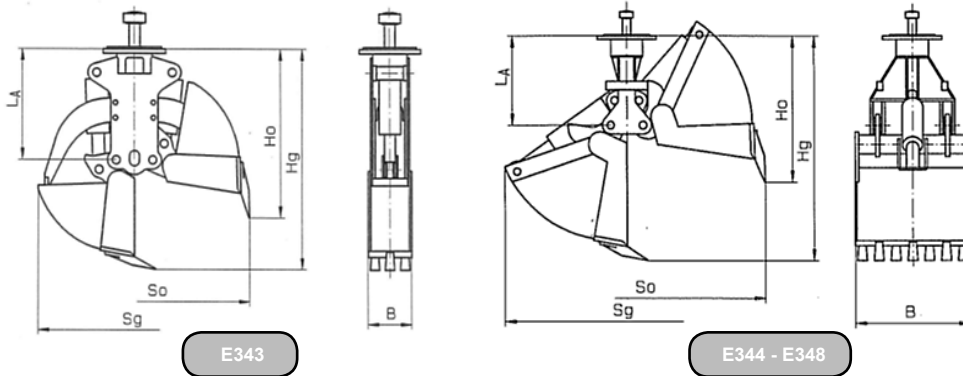

Type designation	Material No	Hg	Ho	La	Sg	So
E343	4584605	1190	905	590	1120	1350
E344	1420942	1295	830	520	1475	1650
E346	1420964	1295	830	520	1475	1650
E348	2580298	1295	830	520	1475	1650
Altitude of rotation gear E332 incl. T31 = 667 mm						
Operating pressure: max 300 bar						



We reserve the right to make technical changes in the course of further development! ATLAS GmbH, 27777 Ganderkesee

ATLAS GmbH - Atlas Str. 6 -27777 Ganderkesee

Tel.: +49 (0) 4222 954-0 -Fax : +49 (0) 4222 954343

Offer list: Attachments for hydraulic excavators

Rail tongs with two vertical grab cylinders and a rotary feed system; short design. A grab rotation gear E 332 is required

Material No.	Type designation	Width		Recommended excavator size	Weight kg
6190118	E343-300-SZ	300 ÖM 510 mm	with 5 t welded load hook	12 - 23 t	365
6191577	E343-600-SZ	600 ÖM 510 mm	with 5 t welded load hook	12 - 23 t	400

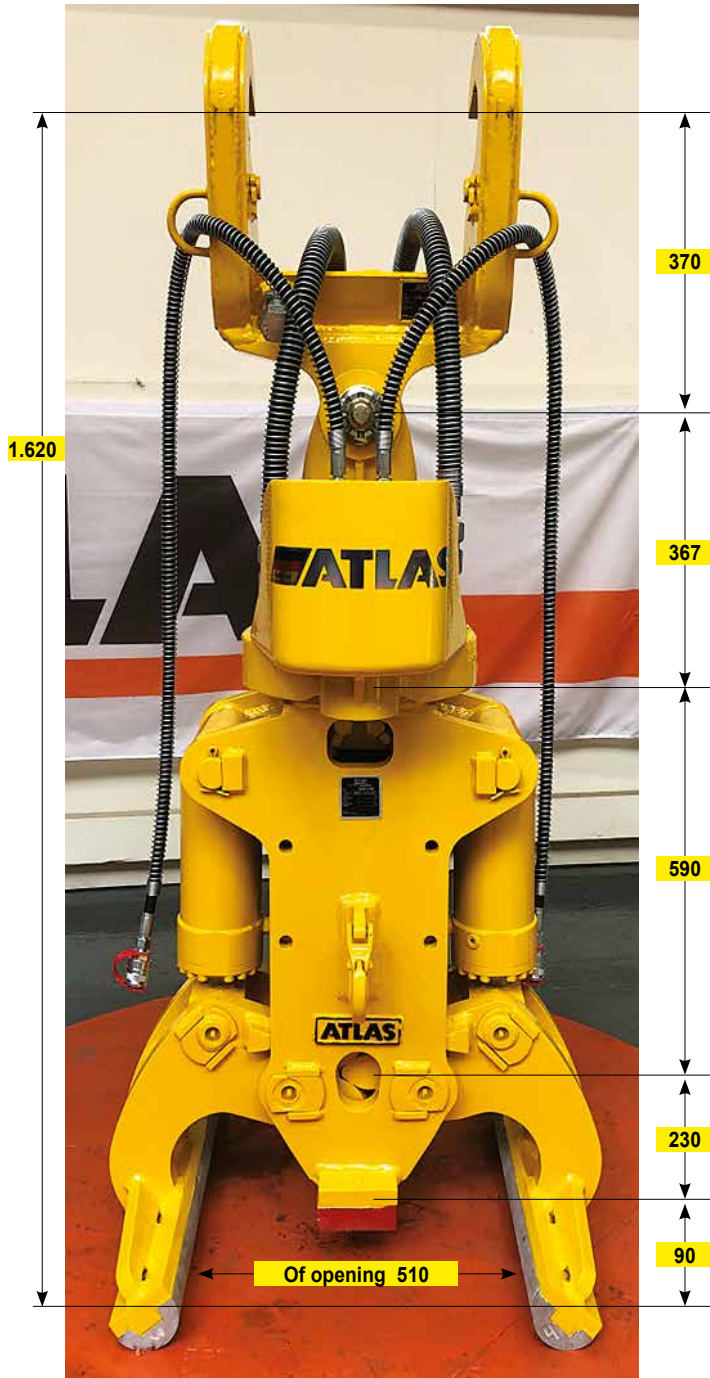

Altitude of rotation gear E332 incl. T630 = 737 mm
Altitude of rotation gear E332 incl. T31 = 667 mm
Operating pressure: max 300 bar

We reserve the right to make technical changes in the course of further development! **ATLAS GmbH**, 27777 Ganderkesee

ATLAS GmbH - Atlas Str. 6 -27777 Ganderkesee

Tel.: +49 (0) 4222 954-0 -Fax : +49 (0) 4222 954343

Offer list: Attachments for hydraulic excavators

Clamshell bucket with a grab cylinder and a rotary feed system, short design, grab rotation gear E 332 is required

Material No.	Type designation	Width	Litres		Recommended excavator size	Weight kg
1597295	E334	Ballast grab Opening dimensions: 800 x 800	110	with an ejector 6 Screw teeth	12 - 23 t	490
1597308	E336	Ballast grab Opening dimensions: 600x1200	200	with an ejector 5 Screw teeth	12 - 23 t	510
4685674	LASTH. 5TO	load hook 5 t for welding				5

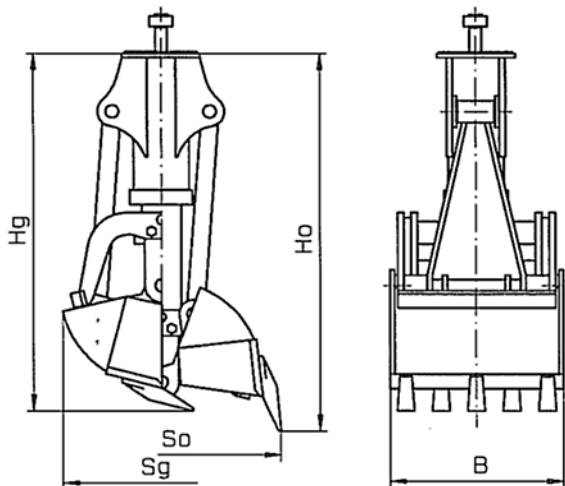

Type designation	Material No	Hg	Ho	Sg	So
E334	1597295	1235	1305	670	800
E336	1597308	1437	1340	1030	1200
Altitude of rotation gear E332 incl. T31 = 667 mm					
Operating pressure: max 300 bar					

We reserve the right to make technical changes in the course of further development! **ATLAS GmbH**, 27777 Ganderkesee

ATLAS GmbH - Atlas Str. 6 -27777 Ganderkesee

Tel.: +49 (0) 4222 954-0 -Fax : +49 (0) 4222 954343

Offer list: Attachmentsfor hydraulic excavators

Clamshell bucket without a grab cylinder Grab rotation gear E 2.62 is required

Material No.	Type designation	Width	Litres		Recommended excavator size	Weight kg
0743780	E2.66	600	450	with an ejector 4 Screw teeth	17 - 35 t	750
0743791	E2.67	850	600	without an ejector 7 Screw teeth	17 - 35 t	890
6014972	E75.32	1210	1200	without an ejector without teeth	17 - 35 t	1195
6000759	E75.33	1210	1500	without an ejector without teeth	17 - 35 t	1270
6152286	E75.33 HD	1210	1500	without an ejector without teeth	17 - 35 t	1290
6144538	E75.35	1460	1800	without an ejector without teeth	25 - 35 t	1280
6023077	E75.36	1610	2000	without an ejector without teeth	25 - 35 t	1340
6174310	E75.36 HD	1610	2000	without an ejector without teeth	25 - 35 t	1510
3592589	E75.37	2010	2500	without an ejector without teeth	25 - 35 t	1480
6150177	E75.38	2010	3000	without an ejector without teeth	25 - 35 t	1550
6089753	E75.40	2610	4000	without an ejector without teeth	25 - 35 t	1800

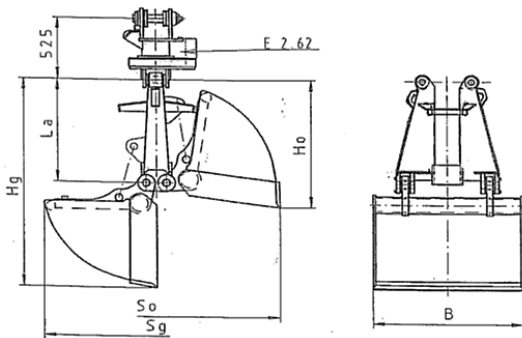

Type designation	Material No	Hg	Ho	La	Sg	So
E2.66	0743780	1690	1125	940	1570	1625
E2.67	0743791	1690	1204	875	1510	1710
E75.32	6014972	1785	1080	875	1800	1940
E75.33	6000759	1885	1090	875	2076	2140
E75.33HD	6152286	1885	1090	875	2076	2140
E75.35	6144538	1885	1090	875	2076	2140
E75.36	6023077	1885	1090	875	2076	2140
E75.36HD	6174310	1885	1090	875	2076	2140
E75.37	3592589	1885	1090	875	2076	2140
E75.38	6150177	1985	1106	875	2276	2337
E75.40	6089753	1985	1106	875	2276	2337

Altitude of rotation gear E2.62 incl. articulation piece T72 = 905 mm

Operating pressure: max 300 bar

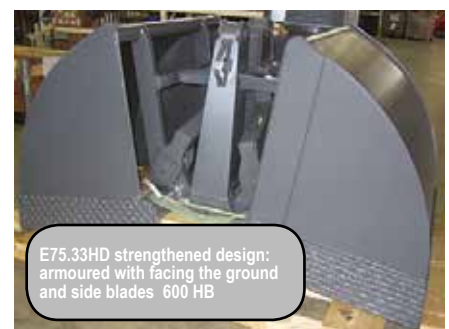

We reserve the right to make technical changes in the course of further development! **ATLAS GmbH**, 27777 Ganderkesee

ATLAS GmbH - Atlas Str. 6 -27777 Ganderkesee

Tel.: +49 (0) 4222 954-0 -Fax : +49 (0) 4222 954343

Offer list: Attachmentsfor hydraulic excavators

Zweischalengreifer mit horizontalem Greiferzylinder Greiferdreheinrichtung E 732-2 erforderlich

Material No.	Type designation	Width	Litres		Recommended excavator size	Weight kg
6173856	E740H-100	1000	1000	without an ejector without teeth	17 - 35 t	1080
6173857	E740H-200	2000	2000	without an ejector without teeth	17 - 35 t	1480

Zweischalengreifer mit horizontalem Greiferzylinder Greiferdreheinrichtung E 832-2 erforderlich

Material No.	Type designation	Width	Litres		Recommended excavator size	Weight kg
6157065	E940H-100	1000	1250	without an ejector without teeth	25 - 50 t	1660
6156173	E940H-200	2000	2500	without an ejector without teeth	25 - 50 t	2070

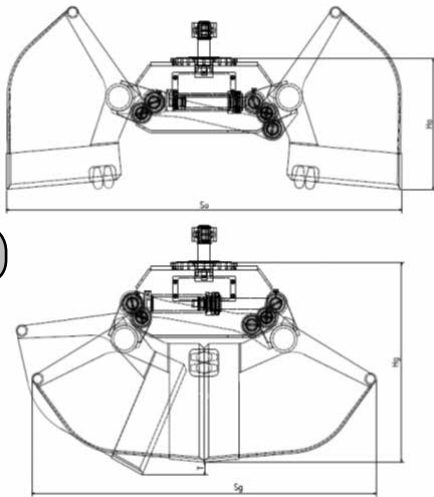

E740H-100
E740H-200



E732-2 5453052
E740H-150WM 6181355
= E740H 1.500mm breit
mit Wendemesser

Type designation	Material No	Hg	Ho	T	Sg	So
E740H-100	6173856	1.114	732	80	1971	2.264
E740H-200	6173857	1.114	732	80	1971	2.264
E940H-100	6157065	1.308	865	95	2245	2.681
E940H-200	6156173	1.325	926	95	2245	2.681

Seitenschnitten Hardox 400
Bodenschnitten Hardox 500



T832 + E832-2 + E940H-100



T82 + E832-2 + E940H-200

We reserve the right to make technical changes in the course of further development! **ATLAS GmbH**, 27777 Ganderkesee

ATLAS GmbH - Atlas Str. 6 -27777 Ganderkesee

Tel.: +49 (0) 4222 954-0 -Fax : +49 (0) 4222 954343

Offer list: Attachments for hydraulic excavators

Grapple and grab for round shafts without a grab cylinder
Grab rotation gear E 32 is required

Material No.	Type designation	Width	DU (Ø) / QM (sq.m.)	Suitable for, and required	Recommended excavator size	Weight kg
1420931	E323	Grab for bundles of wood and tree trunks 600	DU 200 -1.000	E32	12 - 23 t	400
1420895	E324	Round log grab 700	1 QM	E32	12 - 23 t	480

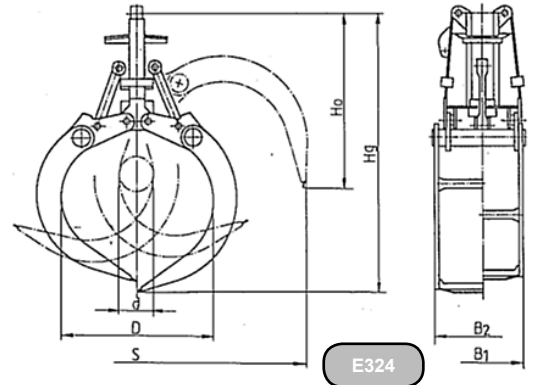
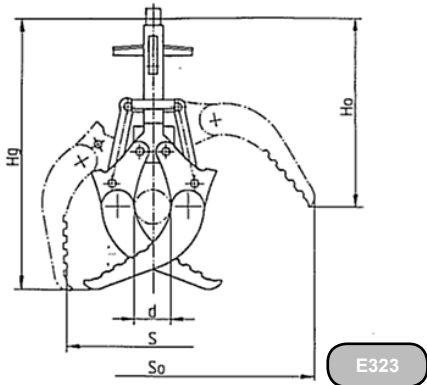

Type designation	Hg	Ho	d	D	S	So	B1	B2
E323	1660	1120	200	.	1030	1880	480	600
E324	2060	1300	250	1160	2420		590	700

Altitude of rotation gear E32 incl. T31 = 951 mm
 Operating pressure: max 300 bar



We reserve the right to make technical changes in the course of further development! **ATLAS GmbH**, 27777 Ganderkesee

ATLAS GmbH - Atlas Str. 6 -27777 Ganderkesee

Tel.: +49 (0) 4222 954-0 -Fax : +49 (0) 4222 954343

Offer list: Attachmentsfor hydraulic excavators

Log grab with a grab cylinder and rotary feed system

Material No.	Type designation	Width	QM	Suitable for, and required	Recommended excavator size	Weight kg
6075763	E624/2V	LOG GRAB 780	1	E732-2	17 - 35 t	1000
6015584	E724/2V	LOG GRAB 800	1.3	E732-2	17 - 35 t	1050
6029406	E824/2V	LOG GRAB 780	1.8	E732-2	25 - 35 t	1075
6068171	E94.61	LOG GRAB 1000	2	E832-2	35 - 50 t	1600
6032675	E924/1H	LOG GRAB 850	2.5	E832-2	35 - 50 t	1680

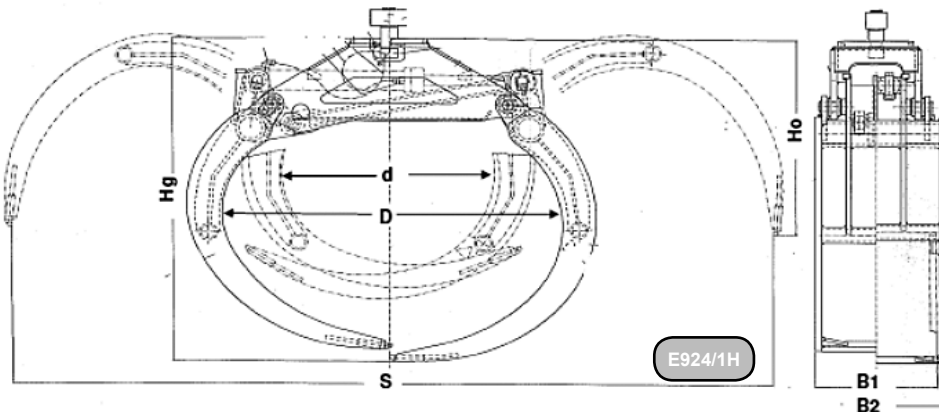
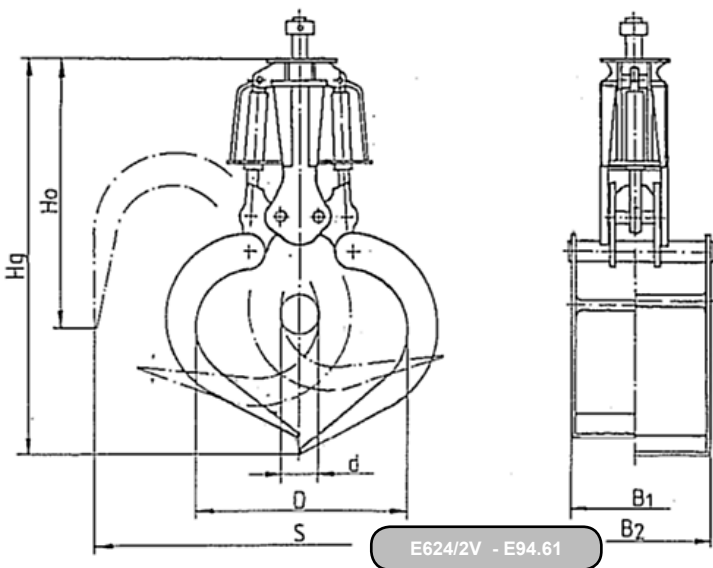

Type designation	Hg	Ho	d	D	S	B1	B2
E624/2V	2050	1280	200	1150	2450	660	780
E724/2V	2260	1300	300	1400	2980	690	800
E824/2V	2500	1370	400	1710	3470	660	780
E94.61	2800	1600	500	1640	3515	865	1000
E924/1H	2137	1290	1270	2020	4530	730	850
Altitude of rotation gear E732 incl. T72 = 796 mm							
Altitude of rotation gear E832 incl. T82 = 940 mm							
Operating pressure max. 300 bar							

We reserve the right to make technical changes in the course of further development! **ATLAS GmbH**, 27777 Ganderkesee

ATLAS GmbH - Atlas Str. 6 -27777 Ganderkesee

Tel.: +49 (0) 4222 954-0 -Fax : +49 (0) 4222 954343

Offer list: Attachments for hydraulic excavators

Grapple and grab for round shafts without a grab cylinder Grab rotation gear E 32 is required

Material No.	Type designation	Width	Litres		Recommended excavator size	Weight kg
1542949	E325	Grapple 1250	650	with an ejector 16 weld-on teeth	12 - 23 t	650
720976	E375	Grab for round shafts Ø 900		with an ejector without teeth	12 - 23 t	330
720987	E376	Grab for round shafts Ø 1.000		with an ejector without teeth	12 - 23 t	370
720998	E377	Grab for round shafts Ø 1.100		with an ejector without teeth	12 - 23 t	480
3514381	E378	Grab for round shafts Ø 1.200		with an ejector without teeth	12 - 23 t	520
6156716	Teeth set for E375 - E378			Optional! (5x 0829589 3 holes) Price incl. drill of the cutting		Extra cost:

Beet grab with two horizontal grab cylinders and rotary feed system, short design, grab rotation gear E 332 is required

Material No.	Type designation	Width	Litres		Recommended excavator size	Weight kg
5433865	E330	1 300	1 000	without an ejector	12 - 23 t	850
5433570	E630	1 650	1 300	without an ejector	12 - 23 t	950
4685674	LASTH. 5TO	load hook 5 t for welding				5

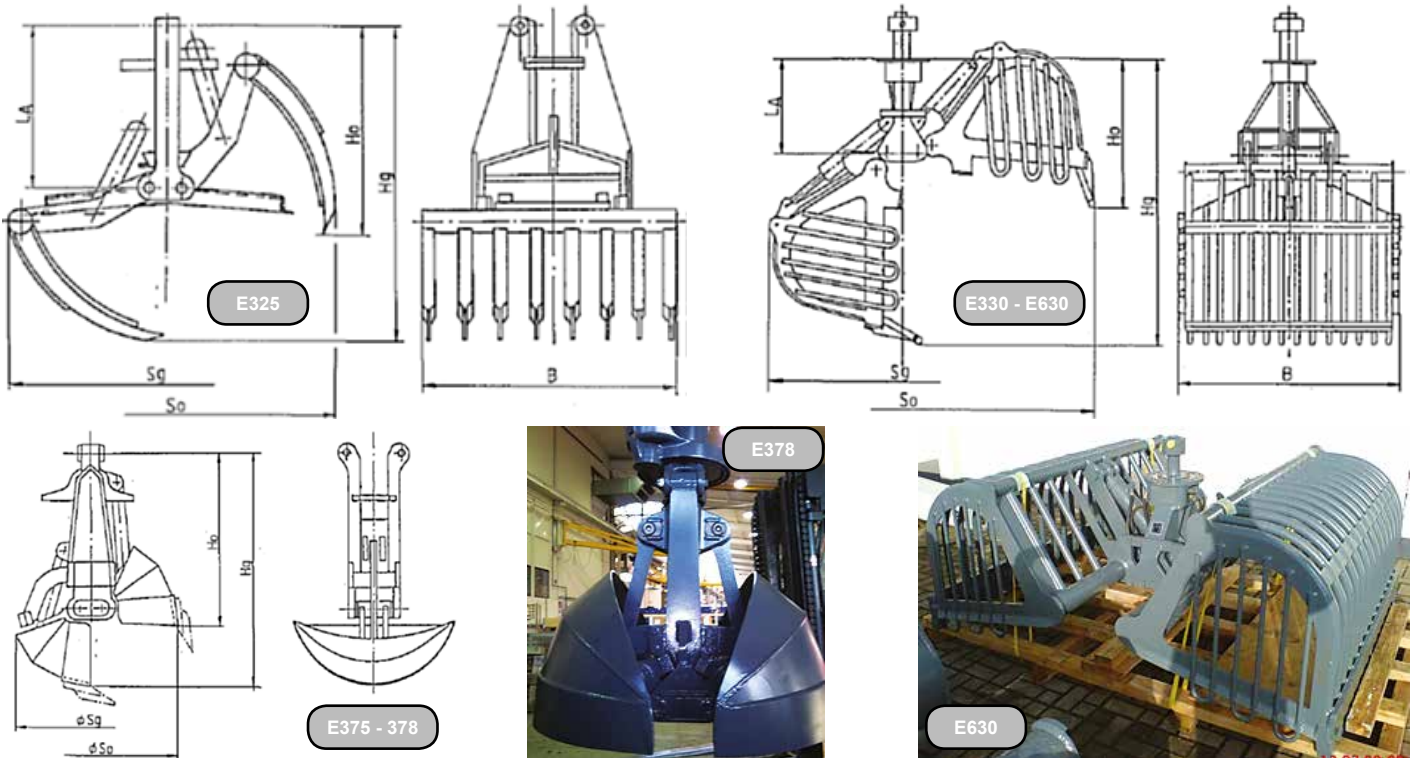

Type designation	Hg	Ho	La	Sg	So
E325	1660	1020	800	1500	1410
E375	1225	970	840	840	DU900
E376	1275	980	840	940	DU1000
E377	1285	950	800	1030	DU1100
E378	1335	960	800	1130	DU1200
E330	1600	860	520	1550	2280
E630	1600	860	520	1550	2280
Altitude of rotation gear E32 incl. T31 = 951 mm					
Altitude of rotation gear E332 incl. T31 = 667 mm					
Operating pressure max.: 300 bar					



We reserve the right to make technical changes in the course of further development! ATLAS GmbH, 27777 Ganderkesee

ATLAS GmbH - Atlas Str. 6 -27777 Ganderkesee

Tel.: +49 (0) 4222 954-0 -Fax : +49 (0) 4222 954343

Offer list: Attachments for hydraulic excavators

Sorting grab, swinging freely

Grab rotation gear E 332 is required

Material No.	Type designation	Width	Litres		Recommended excavator size	Weight kg
5459901	E337 1 Zyl.	1055	300	Metal ribs	13 - 23 t	740

Sorting grab, swinging over a dipper-tipping cylinder for sorting and for light demolition works!

Material No.	Type designation	Width	Litres		Recommended excavator size	Weight kg
6144921	E150-800 1 Zyl.	800	300	Metal ribs	11 - 15 t	740
6145719	E150-800LR 1 Zyl.	800	300	Opening rear wall	11 - 15 t	730
6135271	E200-1000 2 Zyl.	1000	400	Metal ribs	13 - 20 t	1090
6145720	E200-1000LR 2 Zyl.	1000	400	Opening rear wall	13 - 20 t	1070
6144890	E270-1200 2 Zyl.	1200	800	Metal ribs	20 - 27 t	1600
6145731	E270-1200LR 2 Zyl.	1200	800	Opening rear wall	20 - 27 t	1600
6145765	HP E150-270			Hydraulic package		11

Screw adaptor suitable for demolition and sorting grab E150 - E270

6144313	SA-FEST-270	Screw adapter for permanent installation, arm width 268, DU 60				115
6166110	SA-FEST-300	Screw adapter for permanent installation, arm width 300, DU 80				130
6125048	SA-T620	Screw adapter for T620V, T620H				115
6140268	SA-T63.20	Screw adapter for T63.20				190
6135747	SA-MS10	Screw adapter for Lehnhoff MS10				140
6135735	SA-MS21	Screw adapter for Lehnhoff MS21				180
6147869	SA-CW20-40	Screw adapter for Verachtart CW20/40				164
6157024	SA-SW33-E150-270	Screw adapter for Liebherr SW33-E150-270				180
6164922	SA-SW48-E150-270	Screw adapter for Liebherr SW48-E150-270				200
6159207	SA-OQ65	Screw adapter for OilQuick OQ65				350
6168113	SA-OQ70/55	Screw adapter for OilQuick OQ70/55				390

Screw adapter, swinging

6154187	SA-E150-E270-T31	SCREW ADAPTER FIXED SA-E150-E270-T31			100
6159291	SA-E150-E270-T72	SCREW ADAPTER FIXED SA-E150-E270-T72			120

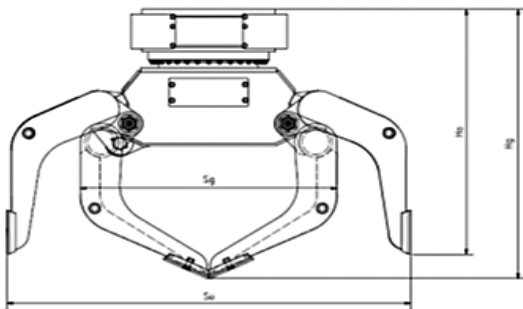

Type designation	Hg	Ho	Sg	So
E337	1040	824	1070	1770
E150-800	1193	1060	1000	1583
E150-800LR	1193	1060	1000	1583
E200-1000	1366	1243	1155	1819
E200-1000LR	1366	1243	1155	1819
E270-1200	1575	1403	1404	2243
E270-1200LR	1575	1403	1404	2243



We reserve the right to make technical changes in the course of further development! ATLAS GmbH, 27777 Ganderkesee

ATLAS GmbH - Atlas Str. 6 -27777 Ganderkesee

Tel.: +49 (0) 4222 954-0 -Fax : +49 (0) 4222 954343

Offer list: Attachmentsfor hydraulic excavators

Multi-jaw grab with 5 grab cylinders and rotary feed system

Grab rotation gear is required

Material No.	Type designation	Grab shells Number and shape	Litres	Suitable for, grab rotation gear	Recommended excavator size	Weight kg
1446191	E121	5 x semi-closed	275	E11.32	6 - 11 t	610
2511762	E122	5 x completely closed	275	E11.32	6 - 11 t	650
4553835	E320	5 x open	350	E732, E732-2	12 - 25 t	995
5448680	E321	5 x semi-closed	350	E732, E732-2	12 - 25 t	1040
6027107	E322	5 x completely closed	350	E732, E732-2	12 - 25 t	1083

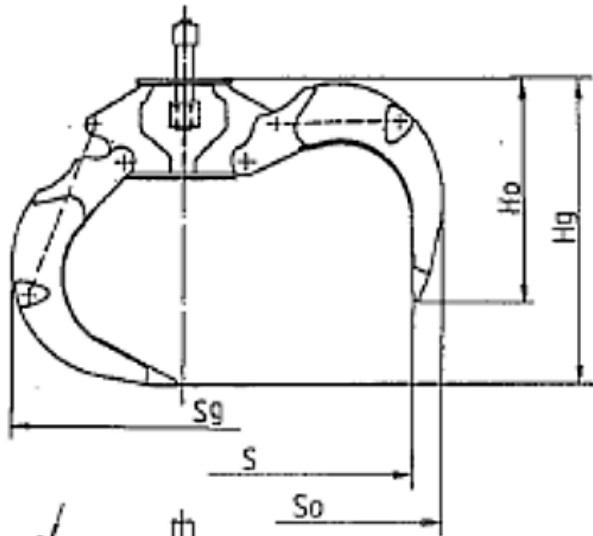

E121

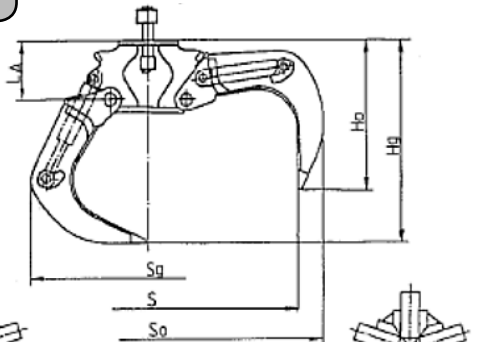

E320

E321 - E322

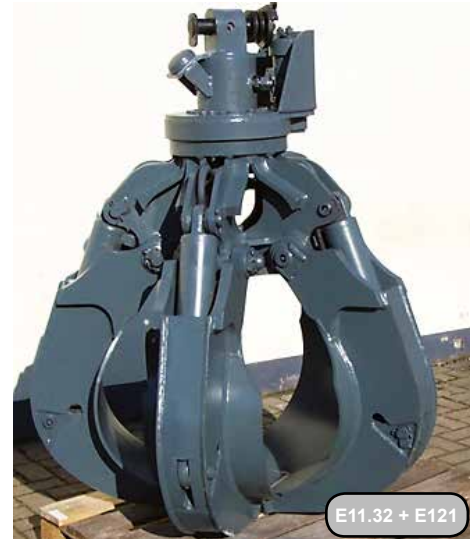

E11.32 + E121



T730 + E732 + E320



E322

Type designation	Hg	Ho	Sg	So	S	B
E121	1035	750	1230	1850	1650	320
E122	1035	750	1230	1850	1650	575
E320	1170	905	1430	2050	1750	200
E321	1170	905	1430	2050	1750	350
E322	1170	905	1430	2050	1750	625

Altitude of rotation gear E11.32 incl. T11.4 = 554 mm Pressure: max 250 bar
 Altitude of rotation gear E732 incl. T64 = 870 mm Pressure: max 300 bar

We reserve the right to make technical changes in the course of further development! ATLAS GmbH, 27777 Ganderkesee

ATLAS GmbH - Atlas Str. 6 -27777 Ganderkesee

Tel.: +49 (0) 4222 954-0 -Fax : +49 (0) 4222 954343

Offer list: Attachments for hydraulic excavators

Multi-jaw grab with 4 grab cylinders and rotary feed system Grab rotation gear is required

Material No.	Type designation	Grab shells Number and shape	Litres	Suitable for, grab rotation gear	Recommended excavator size	Weight kg
6147728	E640-4	4 x open	400	E732, E732-2	17 - 35 t	950
6147894	E641-4	4 x semi-closed	400	E732, E732-2	17 - 35 t	1075
6159978	E642-4	4 x completely closed	400	E732, E732-2	17 - 35 t	1125
6147895	E650-4	4 x open	500	E732, E732-2	17 - 35 t	1000
5403085	E651-4	4 x semi-closed	500	E732, E732-2	17 - 35 t	1125
6121831	E651-4-700-HS	4 shells: 700 mm (width) Tine tips of HARDOX	500 500	E732, E732-2	17 - 35 t	1275
6147896	E750-4	4 x open	600	E732, E732-2	17 - 35 t	1070
6103759	E751-4	4 x semi-closed	600	E732, E732-2	17 - 35 t	1185
6166304	E752-4	4 x completely closed	600	E732, E732-2	17 - 35 t	1330
6147922	E760-4	4 x open	700	E732, E732-2	17 - 35 t	1130
6147923	E761-4	4 x semi-closed	700	E732, E732-2	17 - 35 t	1150
6149607	E770-4	4 x open	800	E732, E732-2	17 - 35 t	1160
6149609	E771-4	4 x semi-closed	800	E732, E732-2	17 - 35 t	1230
6161936	E772-4	4 x completely closed	800	E732, E732-2	17 - 35 t	1380
6147934	E780-4	4 x open	900	E732, E732-2	20 - 35 t	1195
6147935	E781-4	4 x semi-closed	900	E732, E732-2	20 - 35 t	1310
6105402	E790-4	4 x open	1000	E732, E732-2	20 - 35 t	1150
6120825	E791-4	4 x semi-closed	1000	E732, E732-2	20 - 35 t	1235

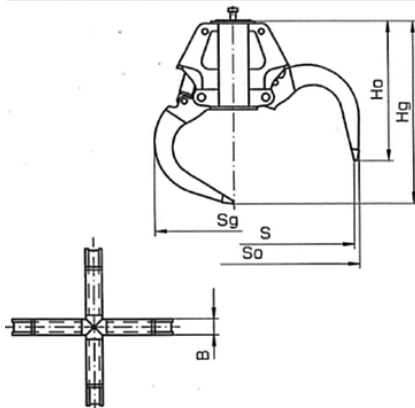

Type designation	Hg	Ho	Sg	So	S	B
E640-4	1620	1293	1345	2130	1346	175
E641-4	1620	1293	1345	2130	1935	450
E642-4	1620	1293	1345	2130	1935	985
E650-4	1700	1325	1400	2280	2080	175
E651-4	1700	1325	1400	2280	2080	450
E651-4-700-HS	1700	1325	1400	2280	2080	700
E750-4	1750	1345	1450	2385	2175	175
E751-4	1750	1345	1450	2380	2175	450
E752-4	1750	1345	1450	2380	2175	1080
E760-4	1780	1352	1480	2420	2230	175
E761-4	1780	1352	1480	2420	2230	450
E770-4	1850	1395	1550	2520	2340	175
E771-4	1850	1395	1550	2520	2340	450
E772-4	1850	1395	1550	2520	2340	1245
E780-4	1910	1435	1620	2640	2440	175
E781-4	1910	1435	1620	2640	2440	450
E790-4	1950	1416	1640	2740	2550	175
E791-4	1950	1416	1640	2740	2550	450

Altitude of rotation gear E732 incl. T72 = 800 mm Pressure: max 300 bar



We reserve the right to make technical changes in the course of further development! ATLAS GmbH, 27777 Ganderkesee

ATLAS GmbH - Atlas Str. 6 -27777 Ganderkesee

Tel.: +49 (0) 4222 954-0 -Fax : +49 (0) 4222 954343

Offer list: Attachments for hydraulic excavators

Multi-jaw grab with 5 grab cylinders and rotary feed system

Grab rotation gear is required

Material No.	Type designation	Grab shells Number and shape	Litres	Suitable for, grab rotation gear	Recommended excavator size	Weight kg
6147727	E640	5 x open	400	E732, E732-2	17 - 35 t	1150
6146940	E641	5 x semi-closed	400	E732, E732-2	17 - 35 t	1265
6147729	E642	5 x completely closed	400	E732, E732-2	17 - 35 t	1280
4538154	E650	5 x open	500	E732, E732-2	17 - 35 t	1200
4532318	E651	5 x semi-closed	500	E732, E732-2	17 - 35 t	1350
6101236	E652	5 x completely closed	500	E732, E732-2	17 - 35 t	1360
4533853	E750	5 x open	600	E732, E732-2	17 - 35 t	1270
4533842	E751	5 x semi-closed	600	E732, E732-2	17 - 35 t	1360
3550976	E752	5 x completely closed	600	E732, E732-2	17 - 35 t	1400
6147897	E760	5 x open	700	E732, E732-2	17 - 35 t	1240
3572369	E761	5 x semi-closed	700	E732, E732-2	17 - 35 t	1380
6147928	E762	5 x completely closed	700	E732, E732-2	17 - 35 t	1520
6149608	E770	5 x open	800	E732, E732-2	17 - 35 t	1280
6149610	E771	5 x semi-closed	800	E732, E732-2	17 - 35 t	1430
6149631	E772	5 x completely closed	800	E732, E732-2	17 - 35 t	1560
6147898	E780	5 x open	900	E732, E732-2	20 - 35 t	1320
6147899	E781	5 x semi-closed	900	E732, E732-2	20 - 35 t	1480
6147931	E782	5 x completely closed	900	E732, E732-2	20 - 35 t	1600
6147900	E790	5 x open	1000	E732, E732-2	20 - 35 t	1350
4558307	E791	5 x semi-closed	1000	E732, E732-2	20 - 35 t	1400
6147929	E792	5 x completely closed	1000	E732, E732-2	20 - 35 t	1760

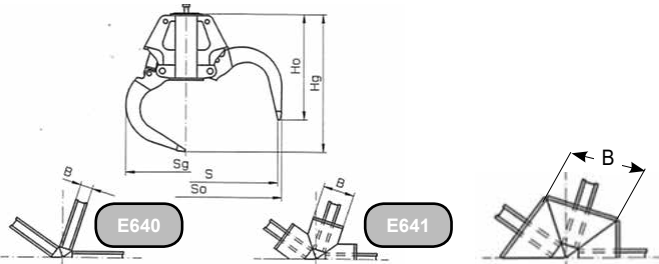

Type designation	Hg	Ho	Sg	So	S	B
E640	1620	1293	1345	2130	1935	175
E641	1620	1293	1345	2130	1935	450
E642	1620	1293	1345	2130	1935	760
E650	1700	1325	1400	2280	2080	175
E651	1700	1325	1400	2280	2080	450
E652	1700	1325	1400	2280	2080	780
E750	1750	1345	1450	2385	2175	175
E751	1750	1345	1450	2385	2175	450
E752	1750	1345	1450	2385	2175	800
E760	1780	1352	1480	2420	2230	175
E761	1780	1352	1480	2420	2230	450
E762	1780	1352	1480	2420	2230	820
E770	1850	1395	1550	2520	2340	175
E771	1850	1395	1550	2520	2340	450
E772	1850	1395	1550	2520	2340	835
E780	1910	1435	1620	2640	2440	175
E781	1910	1435	1620	2640	2440	450
E782	1910	1435	1620	2640	2440	850
E790	1950	1416	1640	2740	2550	175
E791	1950	1416	1640	2740	2550	450
E792	1950	1416	1640	2740	2550	880

Altitude of rotation gear E732 incl. T72 = 800 mm Pressure: max. 300 bar



We reserve the right to make technical changes in the course of further development! ATLAS GmbH, 27777 Ganderkesee

Multi-jaw grab with 4 / 5 grab cylinders and rotary feed system

Grab rotation gear is required

Material No.	Type designation	Grab shells Number and shape	Litres	Suitable for, grab rotation gear	Recommended excavator size	Weight kg
4543822	E850-4	4 x open	700	E832-2	25 - 50 t	1100
4537380	E850	5 x open	700	E832-2	25 - 50 t	1360
6077566	E851-4	4 x semi-closed	700	E832-2	25 - 50 t	1260
4537448	E851	5 x semi-closed	700	E832-2	25 - 50 t	1540
6059333	E852	5 x completely closed	700	E832-2	25 - 50 t	1650
6147924	E860-4	4 x open	900	E832-2	25 - 50 t	1150
4538778	E860	5 x open	900	E832-2	25 - 50 t	1420
4564372	E861-4	4 x semi-closed	900	E832-2	25 - 50 t	1340
4534514	E861	5 x semi-closed	900	E832-2	25 - 50 t	1640
6031873	E862	5 x completely closed	900	E832-2	25 - 50 t	1730
6147925	E94.50-4	4 x open	1100	E832-2	25 - 50 t	1280
6023071	E94.50	5 x open	1100	E832-2	25 - 50 t	1445
6077568	E94.51-4	4 x semi-closed	1100	E832-2	25 - 50 t	1400
6022873	E94.51	5 x semi-closed	1100	E832-2	25 - 50 t	1678
6031869	E94.52	5 x completely closed	1100	E832-2	25 - 50 t	1821
6147926	E94.70-4	4 x open	1400	E832-2	25 - 50 t	1650
6147921	E94.70	5 x open	1400	E832-2	25 - 50 t	1730
6147927	E94.71-4	4 x semi-closed	1400	E832-2	25 - 50 t	1700
6043015	E94.71	5 x semi-closed	1400	E832-2	25 - 50 t	1730
6147930	E94.72	5 x completely closed	1400	E832-2	25 - 50 t	2100

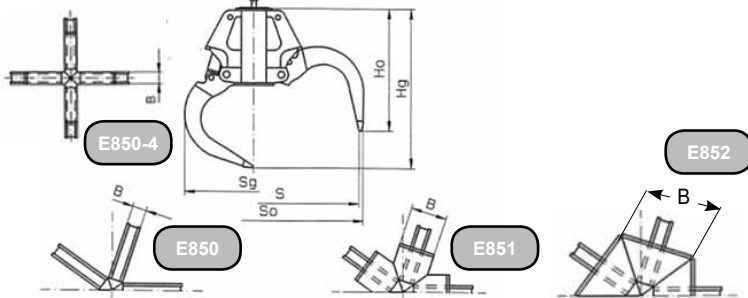

Type designation	Hg	Ho	Sg	So	S	B
E850-4	1820	1430	1520	2460	2260	175
E850	1820	1430	1520	2460	2260	175
E851-4	1820	1430	1520	2460	2500	450
E851	1820	1430	1520	2460	2260	450
E852	1820	1430	1520	2460	2260	840
E860-4	1950	1475	1650	2700	2500	175
E860	1950	1475	1650	2700	2500	175
E861-4	1950	1475	1650	2700	2690	450
E861	1950	1475	1650	2700	2500	450
E862	1950	1475	1650	2700	2500	900
E94.50-4	2050	1515	1734	2890	2260	175
E94.50	2050	1515	1734	2890	2690	175
E94.51-4	2050	1515	1734	2890	2690	450
E94.51	2050	1515	1734	2890	2690	450
E94.52	2050	1515	1734	2890	2690	960
E94.70-4	2150	1551	1872	3102	2872	175
E94.70	2150	1551	1872	3102	2872	175
E94.71-4	2150	1551	1872	3102	2872	450
E94.71	2150	1551	1872	3102	2872	450
E94.72	2150	1551	1872	3102	2872	1050

Altitude of rotation gear E832-2 incl. T82 = 940 mm Pressure: max. 300 bar



ATLAS GmbH - Atlas Str. 6 -27777 Ganderkesee

Tel.: +49 (0) 4222 954-0 -Fax : +49 (0) 4222 954343

Offer list: Attachments for hydraulic excavators

Connecting part for hydraulic hammer

Material No.	Type designation	Suitable for SWE (quick change devices)	Hammer types	Weight kg
4584309	T11.50	T11.20 without screws	HM110, HM135-HM350V	40
3548143	T650	T620V , T620H with screws and nuts 16 x M20x85	KRUPP HM110-HM600 MB700, MB750 MONTABERT BRH250-900, 500, 700, 1000, 501L 640x485x25 base plate	125
5411734	T650 without openings	T620V , T620H	for all purposes without openings 640x485x25 base plate	125
6159805	T650-HM1000	T620V , T620H with screws and nuts 12x M30x100	HM1000, HM1200 640x510x30 base plate	145
4558443	T63.50	T63.20, T63.20H without screws	KRUPP HM350,500,550,560,580,600, KRUPP HM700,711,712,720,800,951,952,960,1000 MONTABERT BRH501,620,625,750,900	200
4543708	T750/2	T722, T722 H without screws	KRUPP HM350,500,550,560,580,600, KRUPP HM700,711,712,720,800,951,952,960,1000 MONTABERT BRH501,620,625,750,900 690x650x30 base plate	214

Connecting plate for welding on the rear side of the dipper

Material No.	Type designation	Suitable for SWE (quick change devices)		Weight kg
4504256	T11.55	T11.20		40
4542252	T652	T620V u T620H	for ATLAS bucket with a cross-tube Ø 178	66
3548121	T655	T620V u T620H		81
6014424	T63.55	T63.20, T63.20H		215
4543731	T755/2	T722, T722 H		230

Adapters for rock buckets and trench diggers

Material No.	Type designation	Suitable for SWE (quick change devices)	a dipper for permanent installation		Weight kg
			Bolts, Ø	Arm width in mm	
3550249	T658	T620V	60	268	130
6027091	T63.58	T63.20, T63.20H	80	300	250



T650 without openings



T658

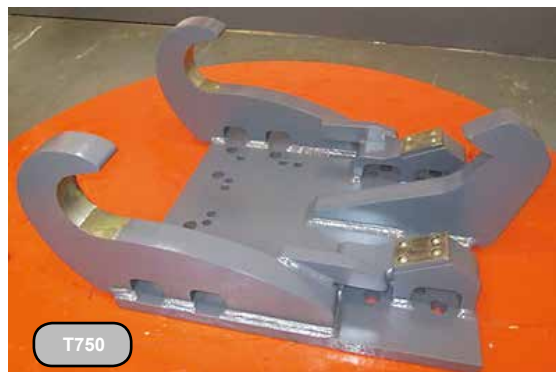

T750

We reserve the right to make technical changes in the course of further development! ATLAS GmbH, 27777 Ganderkesee

Product line of dippers and buckets

The product line of dippers and buckets of ATLAS offers different forms of buckets, capacities and widths for any kind of application, optimally adapted to the relevant carrier:

- Bucket
- Rock bucket
- Trench lining bucket
- Dipper for loamy soil
- Heavy duty fork
- Drainage bucket
- Trench digger
- Multi-purpose dipper

In accordance with the relevant dimensions of the articulated jib ends, the product line of buckets and dippers is divided as follows:

- Dipper attachments for articulated jib end 168 mm (closed) / Ø 50 mm
- Dipper attachments for articulated jib end 268 mm (closed) / Ø 60 mm
- Dipper attachments for articulated jib end 300 mm (closed) / Ø 80 mm
- Dipper attachments for articulated jib end 311 mm (closed) / Ø 80 mm

ATLAS buckets and dippers meet the requirements of the civil engineering:

- The grade of the steel and the special design guarantee stability and wear resistance.
- All parts particularly subject to wear as floor and side blades as well as the floor panel are made of high-strength surface-coated fine-grain structural steel.
- Easy penetration is provided by the free punch due to the slightly conical shape of the dipper. Teeth holders feature flat design and are incorporated in the blade. Flat design provides less digging resistance and high efficiency, for example when unloading, i.e. more work cycles.

For the different types of soil we provide teeth of different shapes:

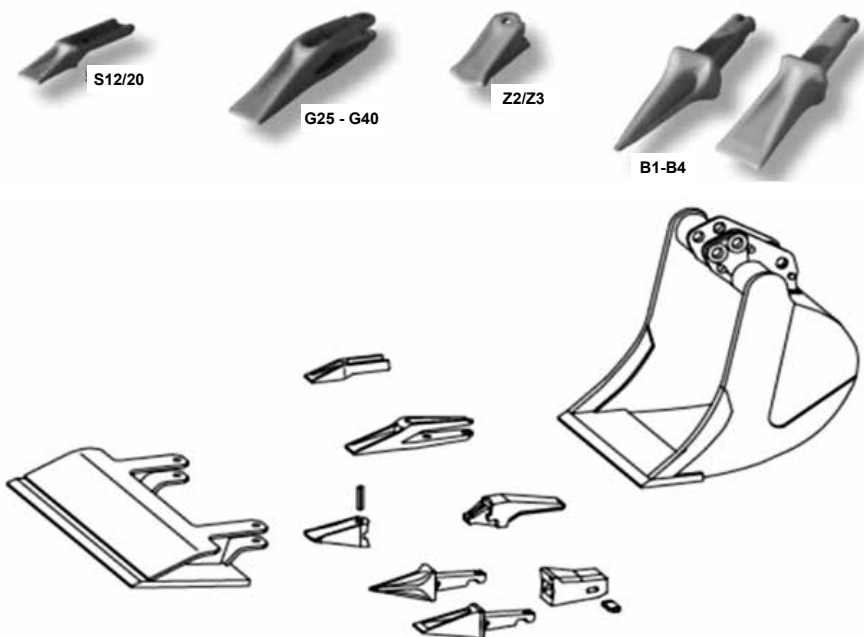

Attachments for dippers

The buckets and dippers are suitable for all kinds of typical application, incl. when high tearing forces are required as for rock breaking off and other demolition works. Teeth are internally welded on and with replaceable tine tips.

Tieflöffel für ATLAS 1004, Zähne innenliegend angeschweißt, auswechselbare Zinkenspitze ATLAS Z2

Material No.	Type designation	Width	Number of teeth	Litres	Suitable for arm width and bolts, Ø (mm), SWE (quick change device)	Recommended excavator size	Weight kg
4569311	F03.12	500	3	230	168/50	6 - 11 t	185
4569322	F03.12SW	500	3	230	T11.20	6 - 11 t	200
4569333	F03.13	600	4	300	168/50	6 - 11 t	210
4569344	F03.13SW	600	4	300	T11.20	6 - 11 t	230
4575400	F03.15	850	5	460	168/50	6 - 11 t	260
4569366	F03.15SW	850	5	460	T11.20	6 - 11 t	280

Bucket for ATLAS 1104 and 1204, teeth are internally welded on and with replaceable ATLAS Z2 tine tips

Material No.	Type designation	Width	Number of teeth	Litres	Suitable for arm width and bolts, Ø (mm), SWE (quick change device)	Recommended excavator size	Weight kg	
4569377	F13.12	500	3	230	268/60	9 - 13 t	210	
4569388	F13.12SW	500	3	230	T620V/T620H	9 - 13 t	250	
4569399	F13.13	600	4	300	268/60	9 - 13 t	245	
4569402	F13.13 SW	600	4	300	T620V/T620H	9 - 13 t	270	
4569413	F13.14	700	4	360	268/60	9 - 13 t	265	
4569424	F13.14SW	700	4	360	T620V/T620H	9 - 13 t	300	
4577457	F13.15	850	5	460	268/60	9 - 13 t	300	
4574523	F13.15 SW	850	5	460	T620V/T620H	9 - 13 t	330	
4569435	F13.16	1000	5	560	268/60	9 - 13 t	330	
4569446	F13.16 SW	1000	5	560	T620V/T620H	9 - 13 t	365	
3130934	LHANBSATZ 5TO.TL	Load hook 5 t for retrofitting						7



F13.13

No additional costs for special colors!



F13.16SW-1150mm
6149218

Special widths with additional costs!

ATLAS GmbH - Atlas Str. 6 -27777 Ganderkesee

Tel.: +49 (0) 4222 954-0 -Fax : +49 (0) 4222 954343

Offer list: Attachments for hydraulic excavators

Bucket: standard design with ATLAS B1 tooth system or a non-serrated blade

Material No.	Type designation	Width	Number of teeth	Litres	Suitable for arm width and bolts, Ø (mm), SWE (quick change device)	Recommended excavator size	Weight kg
3174049	F412	500	3	330	268/60	12 - 17 t	320
6150189	F412 GL.S.	500		330	268/60	12 - 17 t	300
3179204	F412 SW	500	3	330	T620V/T620H	12 - 17 t	320
6017022	F412 SW GL.S.	500		330	T620V/T620H	12 - 17 t	300
4107813	AZS F412	540		Scraper blade above the tine tips			35
3174061	F413	600	3	420	268/60	12 - 17 t	340
3515177	F413 GL.S.	600		420	268/60	12 - 17 t	320
3179259	F413 SW	600	3	420	T620V/T620H	12 - 17 t	370
6149821	F413 SW GL.S.	600		420	T620V/T620H	12 - 17 t	350
3532214	AZS F413	640		Scraper blade above the tine tips			50
3171422	F415	850	4	670	268/60	12 - 17 t	430
3519013	F415 GL.S.	850		670	268/60	12 - 17 t	390
3175175	F415 SW	850	4	670	T620V/T620H	12 - 17 t	450
3552876	F415SW GL.S.	850		670	T620V/T620H	12 - 17 t	415
3532236	AZS F415	890		Scraper blade above the tine tips			63
3174129	F416	1000	5	820	268/60	12 - 17 t	480
3518589	F416 GL.S.	1000		820	268/60	12 - 17 t	450
3186236	F416 SW	1000	5	820	T620V/T620H	12 - 17 t	500
3513277	F416 SW GL.S.	1000		820	T620V/T620H	12 - 17 t	470
4100576	AZS F416	1040		Scraper blade above the tine tips			70
3174141	F417	1100	5	920	268/60	12 - 17 t	510
3081752	F417 GL.S.	1100		920	268/60	12 - 17 t	450
3186156	F417 SW	1100	5	920	T620V/T620H	12 - 17 t	550
3561800	F417 SW GL.S.	1100		920	T620V/T620H	12 - 17 t	500
4100996	AZS F417	1140		Scraper blade above the tine tips			80
6124924	F417SW-SR	1100	5	920	T620V/T620H	12 - 17 t	610
3174163	F418	1300	6	1120	268/60	12 - 17 t	550
3512425	F418 GL.S.	1300		1120	268/60	12 - 17 t	530
3186178	F418 SW	1300	6	1120	T620V/T620H	12 - 17 t	600
3503957	F418 SW GL.S.	1300		1120	T620V/T620H	12 - 17 t	550
4107835	AZS F418	1340		Scraper blade above the tine tips			90
3130934	LHANBSATZ 5TO.TL			Load hook 5 t for retrofitting			7

Additional prices for the above listed buckets en dippers - from other manufacturers suitable for quick change connectors - see page 34



F415SW



F415MS10



F417SW-SR
Stegabstand
75mm



Scraper blade
mounted at F413



F415 Permanent
installation



F416SW48
LIKUFIX



F416 CW20-40

We reserve the right to make technical changes in the course of further development! ATLAS GmbH, 27777 Ganderkesee

ATLAS GmbH - Atlas Str. 6 -27777 Ganderkesee

Tel.: +49 (0) 4222 954-0 -Fax : +49 (0) 4222 954343

Offer list: Attachments for hydraulic excavators

Quick change connectors from other manufacturers

Additional price for Backhoe and rock bucket -suitable for T620V / T620H

Deliverable for manufacturer	Type designation	for bucket size
Lehnhoff	MS10	F412SW - F648SW
Lehnhoff	MS21 / 25	F412SW - F648SW
Verachttert	CW20-40	F415SW - F648SW
SMP	SMP 2 STD	F413SW - F648SW
SMP	SMP 2 Euro	F413SW - F648SW
Liebherr	SW33	F412SW - F648SW
Liebherr	SW33 LIKU	F412SW - F648SW
Liebherr	SW48	F414SW - F648SW
Liebherr	SW48 LIKU	F414SW - F648SW
Oil Quick	OQ65 / OQ RAIL	F414SW - F648SW
Oil Quick	OQ70	F414SW - F648SW
Oil Quick	OQ70 / 55	F415SW - F648SW



F415MS10



F416CW20-40



F416SW48 LIKUFIX



F415OQ65

We reserve the right to make technical changes in the course of further development! **ATLAS GmbH**, 27777 Ganderkesee

ATLAS GmbH - Atlas Str. 6 -27777 Ganderkesee

Tel.: +49 (0) 4222 954-0 -Fax : +49 (0) 4222 954343

Offer list: Attachments for hydraulic excavators

Rock bucket - HD-design with wear plates and ATLAS B2 tooth system

Material No.	Type designation	Width	Number of teeth	Litres	Suitable for arm width and bolts, Ø (mm), SWE (quick change device)	Recommended excavator size	Weight kg
3174083	F643	600	3	420	268/60	15 - 20 t	400
3186190	F643SW	600	3	420	T620V/T620H	15 - 20 t	440
3172003	F645	850	4	670	268/60	15 - 20 t	500
3186214	F645SW	850	4	670	T620V/T620H	15 - 20 t	540
3174185	F647	1100	5	920	268/60	15 - 20 t	620
3186134	F647 SW	1100	5	920	T620V/T620H	15 - 20 t	660
3174209	F648	1300	5	1120	268/60	15 - 20 t	660
3186112	F648SW	1300	5	1120	T620V/T620H	15 - 20 t	700

Additional prices for the above listed buckets en dippers - from other manufacturers suitable for quick change connectors - see page 34

4569457	F63.23	600	3	430	300/80	17 - 25 t	480
4569468	F63.23SW	600	3	430	T63.20/T63.20H	17 - 25 t	530
4569479	F63.24	700	4	530	300/80	17 - 25 t	535
4569480	F63.24 SW	700	4	530	T63.20/T63.20H	17 - 25 t	590
4569491	F63.25	850	4	670	300/80	17 - 25 t	590
4569004	F63.25 SW	850	4	670	T63.20/T63.20H	17 - 25 t	645
4569060	F63.15	850	4	750	300/80	17 - 25 t	640
4569071	F63.15 SW	850	4	750	T63.20/T63.20H	17 - 25 t	670
4569015	F63.26	1000	4	830	300/80	17 - 25 t	635
4569026	F63.26 SW	1000	4	830	T63.20/T63.20H	17 - 25 t	690
4574421	F63.27	1100	5	930	300/80	17 - 25 t	680
4569037	F63.27 SW	1100	5	930	T63.20/T63.20H	17 - 25 t	740
4574432	F63.28	1300	5	1140	300/80	17 - 25 t	780
4569048	F63.28 SW	1300	5	1140	T63.20/T63.20H	17 - 25 t	815
4573522	F63.29	1500	6	1340	300/80	17 - 25 t	840
4569059	F63.29 SW	1500	6	1340	T63.20/T63.20H	17 - 25 t	895
3130934	LHANBSATZ 5TO.TL.S				Load hook 5 t for retrofitting		7



We reserve the right to make technical changes in the course of further development! **ATLAS GmbH**, 27777 Ganderkesee

ATLAS GmbH - Atlas Str. 6 -27777 Ganderkesee

Tel.: +49 (0) 4222 954-0 -Fax : +49 (0) 4222 954343

Offer list: Attachments for hydraulic excavators

Rock bucket - HD-design with wear plates and tooth system

Material No.	Type designation	Width	Number of teeth	Litres	Suitable for arm width and bolts, Ø (mm), SWE (quick change device)	Recommended excavator size	Weight kg
3177768	F748	1300	5	1260	forked/80	22 - 28 t	930
3564143	F748 SW	1300	5	1260	T722/T722H	22 - 28 t	980
3177848	F718	1500	5	1500	forked/80	22 - 28 t	1005
3564110	F718 SW	1500	5	1500	T722/T722H	22 - 28 t	1070
3130934	LHANBSATZ 5TO.TL.S				Load hook 5 t for retrofitting		7

Rock bucket - HD-design with wear plates and tooth system and load hook 12,5 t. outside SW (quick coupler) dipper

Material No.	Type designation	Width	Number of teeth	Litres	Suitable for arm width and bolts, Ø (mm), SWE (quick change device)	Recommended excavator size	Weight kg
3183415	F847	1000	3	910	forked/80	28 - 35 t	800
3564325	F847 SW	1000	3	910	T722/T722H	28 - 35 t	850
3183528	F849	1500	5	1500	forked/80	28 - 35 t	1140
3564267	F849 SW	1500	5	1500	T722/T722H	28 - 35 t	1200

Rock bucket - HD-design with wear plates suitable for 210 - 260LC with CAT tooth system

Material No.	Type designation	Width	Number of teeth	Litres	Suitable for arm width and bolts, Ø (mm), SWE (quick change device)	Recommended excavator size	Weight kg
6149301	F75.15	850	4x 1U3352	680	311/80	22 - 28 t	750
6083115	F75.15MS21	850	4x 1U3352	680	Lehnhoff MS21	22 - 28 t	680
6149303	F75.17	1100	5x 1U3352	940	311/80	22 - 28 t	800
6083119	F75.17MS21	1100	5x 1U3352	940	Lehnhoff MS21	22 - 28 t	730
6149305	F75.18	1300	5x 1U3352	1160	311/80	22 - 28 t	850
6083132	F75.18MS21	1300	5x 1U3352	1160	Lehnhoff MS21	22 - 28 t	780
6149306	F75.09	1500	6x 1U3352	1370	311/80	22 - 28 t	1040
6091486	F75.09MS21	1500	6x 1U3352	1370	Lehnhoff MS21	22 - 28 t	970
6101086	F75.29	1600	6x 1U4452	1650	311/80	22 - 28 t	1420
6123181	F75.29MS21	1600	6x 1U4452	1650	Lehnhoff MS21	22 - 28 t	1350
3130934	LHANBSATZ 5TO.TL.S				Load hook 5 t for retrofitting		7



ATLAS GmbH - Atlas Str. 6 -27777 Ganderkesee

Tel.: +49 (0) 4222 954-0 -Fax : +49 (0) 4222 954343

Offer list: Attachments for hydraulic excavators

Drainage bucket

Suitable for application in sticky material

Scope of delivery: Screw teeth, hydr. ejectors, 2 hoses

Material No.	Type designation	Width	Number of teeth	Litres	Suitable for arm width and bolts, Ø (mm), SWE (quick change device)	Recommended excavator size	Weight kg
3077814	F17.2	300	2 G25	130	168/50	6 - 11 t	220
3507893	F17.2SW	300	2 G25	130	T11.20	6 - 11 t	240
3507837	F17.3	400	3 G25	190	168/50	6 - 11 t	240
3507928	F17.3SW	400	3 G25	190	T11.20	6 - 11 t	260
3080148	F402	300	2 G30	200	268/60	12 - 20 t	310
3080171	F402SW	300	2 G30	200	T620V/T620H	12 - 20 t	375
6173322	F402MS10	300	2 G30	200	Lehnhoff MS10	12 - 20 t	375
3080160	F403	400	3 G30	285	268/60	12 - 20 t	345
3080182	F403SW	400	3 G30	285	T620V/T620H	12 - 20 t	410
6068774	F403MS10	400	3 G30	285	Lehnhoff MS10	12 - 20 t	410

Trench lining bucket: flat shape, with a non-serrated blade

Material No.	Type designation	Width	Litres	Suitable for arm width and bolts, Ø (mm), SWE (quick change device)	Recommended excavator size	Weight kg
3171875	F435	850	490	268/60	10 - 20 t	290
3183631	F435SW	850	490	T620V/T620H	10 - 20 t	315
respectively with openings in the floor blade for 4 teeth 3604459						
4569082	F63.35	850	530	300/80	17 - 25 t	420
4569093	F63.35SW	850	530	T63.20/T63.20H	17 - 25 t	510

Universaltieflöffel, runde Form für leichte Böden, glatte Schneide

Material No.	Type designation	Width	Litres	Suitable for arm width and bolts, Ø (mm), SWE (quick change device)	Recommended excavator size	Weight kg
3159551	F438	1300	1100	268/60	12 - 20 t	440
3186054	F438SW	1300	1100	T620V/T620H	12 - 20 t	480
respectively with openings in the floor blade for 5 teeth 3604459						

Lehmlöffel, schlanke Löffelform, without an ejector

Material No.	Type designation	Width	Litres	Suitable for arm width and bolts, Ø (mm), SWE (quick change device)	Recommended excavator size	Weight kg
3569488	F01.4	400	200	168/50	6 - 11 t	140
3589813	F01.4SW	400	200	T11.20	6 - 11 t	172
respectively with openings in the floor blade for 3 teeth 3646766						
3171717	F454	400	260	268/60	10 - 20 t	220
3186098	F454SW	400	260	T620V/T620H	10 - 20 t	265
respectively with openings in the floor blade for 2 teeth 3604459						
3171739	F455	500	350	268/60	10 - 20 t	245
3186076	F455SW	500	350	T620V/T620H	10 - 20 t	280
6019753	F456	600	400	268/60	10 - 20 t	270
6019755	F456SW	600	400	T620V/T620H	10 - 20 t	300
respectively with openings in the floor blade for 3 teeth 3604459						



We reserve the right to make technical changes in the course of further development! ATLAS GmbH, 27777 Ganderkesee

ATLAS GmbH - Atlas Str. 6 -27777 Ganderkesee

Tel.: +49 (0) 4222 954-0 -Fax : +49 (0) 4222 954343

Offer list: Attachments for hydraulic excavators

**Trench digger with a rear blade and with
screwed floor blade, fixed
with water holes in the rear wall up to G69SW**

Material No.	Type designation	Width	Litres	Suitable for arm width and bolts, Ø (mm), SWE (quick change device)	Recommended excavator size	Weight kg
2232242	G11.2	1500	260	168/50	6 - 11 t	225
3110429	G11.2SW	1500	260	T11.20	6 - 11 t	235
1446351	G62	2000	400	268/60	12 - 20 t	345
2213669	G62SW	2000	400	T620V/T620H	12 - 20 t	360
1446373	G64	2000	560	268/60	12 - 20 t	405
2213647	G64SW	2000	560	T620V/T620H	12 - 20 t	415
6177733	G64SW o.WL.	2000	560	T620V/T620H	12 - 20 t	418
6132650	G64MS10	2000	560	Lehnhoff MS10	12 - 20 t	505
1446384	G69	2200	700	268/60	12 - 20 t	480
2213636	G69SW	2200	700	T620V/T620H	12 - 20 t	490
3084562	G624 o.WL.	2000	800	268/60	12 - 20 t	600
3551148	G624SW o.WL.	2000	800	T620V/T620H	12 - 20 t	610
G624 equipped as a tool carrier, no rear blade, with a holder for pallet						
4569128	G63.34	2000	710	300/80	17 - 25 t	590
4569139	G63.34SW	2000	710	T63.20/T63.20H	17 - 25 t	670
4569140	G63.36	2000	900	300/80	17 - 25 t	615
4569151	G63.36SW	2000	900	T63.20/T63.20H	17 - 25 t	695



G11.2



G644MS10



G69SW



G64SW



Extra work attachments upon customer request, for example:
6143861 G64SW 3000mm Sonder

We reserve the right to make technical changes in the course of further development! **ATLAS GmbH**, 27777 Ganderkesee

Trench digger with a rear blade and screwed floor blade, swivelling: 2 x 45 degrees, incl. 2 hydraulic swivelling cylinders with hoses up to the articulated jib with water holes in the rear wall up to G649MS21

Material No.	Type designation	Width	Litres	Suitable for arm width and bolts, Ø (mm), SWE (quick change device)	Recommended excavator size	Weight kg
3560092	G11.42	1500	260	168/50	6 - 11 t	280
3560105	G11.42SW	1500	260	T11.20	6 - 11 t	310
4569220	G13.42	1500	260	268/60	9 - 13 t	525
4569231	G13.42SW	1500	260	T620V/T620H	9 - 13 t	540
4105117	G642	2000	400	268/60	12 - 23 t	550
4105140	G642SW	2000	400	T620V/T620H	12 - 23 t	570
4105162	G644	2000	560	268/60	12 - 23 t	580
4105195	G644SW	2000	560	T620V/T620H	12 - 23 t	670
3565291	G644 O.WL.	2000	560	268/60	12 - 23 t	595
3565304	G644SW O.WL.	2000	560	T620V/T620H	12 - 23 t	670
4551162	G649	2200	700	268/60	12 - 23 t	630
4551184	G649SW	2200	700	T620V/T620H	12 - 23 t	705
Additional prices for the above listed trench diggers - from other manufacturers suitable for quick change connectors - see page 42						
6025229	G53.45	2000	650	268/60	12 - 23 t	615
hydraulic cylinder installed for protection, with a complete cylinder cover without water holes in the rear wall						
6030801	G53.45SW	2000	650	T620V/T620H	12 - 23 t	700
hydraulic cylinder installed for protection, with a complete cylinder cover without water holes in the rear wall						
4569184	G63.44	2000	710	300/80	17 - 25 t	955
4569195	G63.44SW	2000	710	T63.20/T63.20H	17 - 25 t	1050
4569208	G63.46	2000	900	300/80	17 - 25 t	995
4569219	G63.46SW	2000	900	T63.20/T63.20H	17 - 25 t	1100
6149280	G75.53	2000	860	311/80	22 - 28 t	980
6117682	G75.53MS21	2000	860	Lehnhoff MS21	22 - 28 t	980
4902258	G742	2200	910	forked/80	22 - 35 t	1005
5412837	G742SW	2200	910	T722/T722H	22 - 35 t	1100

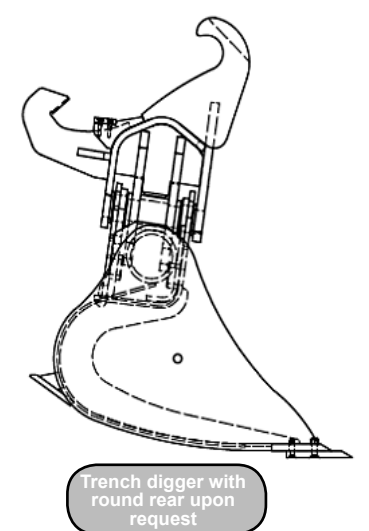

Trench digger with round rear upon request

We reserve the right to make technical changes in the course of further development! ATLAS GmbH, 27777 Ganderkesee

ATLAS GmbH - Atlas Str. 6 -27777 Ganderkesee

Tel.: +49 (0) 4222 954-0 -Fax : +49 (0) 4222 954343

Offer list: Attachments for hydraulic excavators

Trench digger, bucket shape with rear blade and fixed to the ground or swivelling 2 x 45 degrees with 2 hydraulic swivelling cylinders with hoses up to the articulated jib with water holes in the rear wall

Material No.	Type designation	Version	Width	Litres	Suitable for arm width and bolts, Ø (mm), SWE (quick change device)	Recommended excavator size	Weight kg
6182706	G54	fixed	2000	580	268/60	12 - 23 t	450
6179565	G54SW	fixed	2000	580	T620V/T620H	12 - 23 t	450
6182707	G55	fixed	2000	780	268/60	12 - 23 t	490
6167787	G55SW	fixed	2000	780	T620V/T620H	12 - 23 t	490
6156986	G654	2x45deg.	2000	580	268/60	12 - 23 t	600
6156981	G654SW	2x45deg.	2000	580	T620V/T620H	12 - 23 t	640
6156825	G655	2x45deg.	2000	780	268/60	12 - 23 t	650
6156789	G655SW	2x45deg.	2000	780	T620V/T620H	12 - 23 t	670



G54SW



G655SW

Trench digger, bucket shape with rear blade and fixed or swivelling 2 x 50 degrees with rotator HKS Xtra Tilt 250, with hoses up to the articulated jib with water holes in the rear wall

Material No.	Type designation	Width	Litres	Recommended excavator size	Weight kg
6182708	G654 Body with rotator	2000	580	12 - 23 t	750
6173386	G655 Body with rotator	2000	780	12 - 23 t	800

Other bodyshapes upon request!!

Screw adaptor suitable for trench digger

6173387	SA-G-T620	Screw plate for T620V/T620H	125
6173388	SA-G-MS10	Screw plate for Lehnhoff MS10	135
6173389	SA-G-CW20-40	Screw plate for Verachttert CW20-40	120
6182709	SA-G-OQ65	Screw plate for Oil Quick OQ65	115
6180894	SA-G-OQ70/55	Screw plate for Oil Quick OQ70/55	125

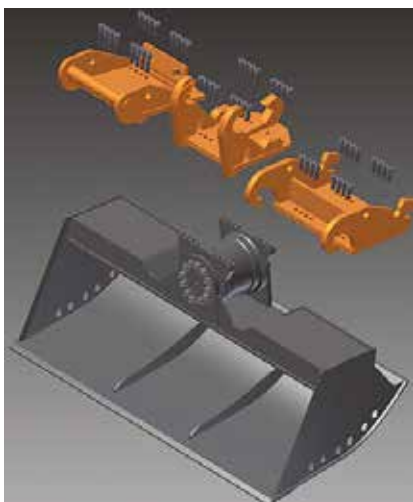

Screw plate for T620V/T620H Body G655 with rotator

We reserve the right to make technical changes in the course of further development! ATLAS GmbH, 27777 Ganderkesee

ATLAS GmbH - Atlas Str. 6 -27777 Ganderkesee

Tel.: +49 (0) 4222 954-0 -Fax : +49 (0) 4222 954343

Offer list: Attachments for hydraulic excavators

**Multi-purpose bucket, bucket shape without rear blade, with non-serrated floor blade, fixed
G475 - G 477SW floor panel from 400HB special steel**

Material No.	Type designation	Width	Litres	Suitable for arm width and bolts, Ø (mm), SWE (quick change device)	Recommended excavator size	Weight kg
3174265	G475	1500	750	268/60	12 - 23 t	370
3186032	G475SW	1500	750	T620V/T620H	12 - 23 t	410
3174298	G476	1750	890	268/60	12 - 23 t	420
3186010	G476SW	1750	890	T620V/T620H	12 - 23 t	460
3174323	G477	2000	1020	268/60	12 - 23 t	450
3185995	G477SW	2000	1020	T620V/T620H	12 - 23 t	500
4568785	G63.76	1750	1230	300/80	17 - 25 t	590
4568796	G63.76SW	1750	1230	T63.20/T63.20H	17 - 25 t	680
4568809	G63.77	2000	1420	300/80	17 - 25 t	655
4568810	G63.77SW	2000	1420	T63.20/T63.20H	17 - 25 t	790
4573884	G83.76	2000	1600	forked/80	22 - 35 t	825
4550490	G83.76SW	2000	1600	T722/T722H	22 - 35 t	920

**Multi-purpose bucket, round bucket shape without rear blade, with non-serrated floor blade, swivelling 2 x 45 degrees, incl. 2 hydraulic swivelling cylinders with hoses up to the articulated jib
G485 - G 487MS21 floor panel from 400HB special steel**

Material No.	Type designation	Width	Litres	Suitable for arm width and bolts, Ø (mm), SWE (quick change device)	Recommended excavator size	Weight kg
4573862	G485	1500	750	268/60	12 - 23 t	575
4557033	G485SW	1500	750	T620V/T620H	12 - 23 t	650
4573840	G486	1750	890	268/60	12 - 23 t	610
4557055	G486SW	1750	890	T620V/T620H	12 - 23 t	675
4573828	G487	2000	1020	268/60	12 - 23 t	660
4557077	G487SW	2000	1020	T620V/T620H	12 - 23 t	735
4568821	G63.86	1750	1230	300/80	17 - 25 t	960
4568832	G63.86SW	1750	1230	T63.20/T63.20H	17 - 25 t	1055
4568843	G63.87	2000	1420	300/80	17 - 25 t	1010
4568854	G63.87SW	2000	1420	T63.20/T63.20H	17 - 25 t	1115
4573873	G83.86	2000	1600	forked/80	22 - 35 t	1180
5400015	G83.86SW	2000	1600	T722/T722H	22 - 35 t	1230



G477SW



G486



G63.87SW



G487SW



G487OQ70-55 6179386

We reserve the right to make technical changes in the course of further development! ATLAS GmbH, 27777 Ganderkesee

ATLAS GmbH - Atlas Str. 6 -27777 Ganderkesee

Tel.: +49 (0) 4222 954-0 -Fax : +49 (0) 4222 954343

Offer list: Attachments for hydraulic excavators

Quick change connectors from other manufacturers suitable for trench digger

Additional proce for swivelling trench digger of G13.42SW, G485SW-G487SW, G642-G655SW

Material No.	Deliverable for manufacturer	Type designation	for bucket size
	Lehnhoff	MS10	G13.42SW - G655SW
	Lehnhoff	MS21/25	G13.42SW - G655SW
	Verachtert	CW20-40	G13.42SW - G655SW
	SMP	SMP 2 STD	G13.42SW - G655SW
	SMP	SMP 2 Euro	G13.42SW - G655SW
	Liebherr	SW33	G13.42SW - G655SW
	Liebherr	SW33 LIKU	G13.42SW - G655SW
	Liebherr	SW48	G13.42SW - G655SW
	Liebherr	SW48 LIKU	G13.42SW - G655SW
	Oil Quick	OQ65	G13.42SW - G655SW
	Oil Quick	OQ70	G13.42SW - G655SW
	Oil Quick	OQ70/55	G13.42SW - G655SW
	Oil Quick	OQZAIL	G13.42SW - G655SW



We reserve the right to make technical changes in the course of further development! **ATLAS GmbH**, 27777 Ganderkesee

ATLAS GmbH - Atlas Str. 6 -27777 Ganderkesee

Tel.: +49 (0) 4222 954-0 -Fax : +49 (0) 4222 954343

Offer list: Attachments for hydraulic excavators

SWINGOTILT

The SWINGOTILT with 2 double-acting cylinders can be swivelled 2x40 ° and rotated 360 ° endlessly

Material no.	Type designation	Suitable for arm width and bolts, Ø (mm), SWE (quick change device)	Recommended excavator size	Weight (kg)
6197760	ST15-T620 o.Mg.V.	T620V/T620H	10 - 15 t	400
6196620	ST18-T620 o.Mg.V.	T620V/T620H	14 - 18 t	500
6206895	ST22-T620 o.Mg.V.	T620V/T620H	16 - 22 t	620
6145950	ST15-22 HP	Hydraulic package	T620V/T620H	11

Hydraulic mounting kits on the machine are required:

Two-way

6181511 Hydraulic mounting kit Comfort: Tool control for 16 different working tools via potentiometer adjustable from the cab (e.g. flail mower, mowing bucket, branch cutter, vibration bear, hydraulic hammer). Consisting of pressure compensation valve with electronic control for oil quantity and pressure.

3082106 Hydraulic attachment kit, for K-sorting grab, piping up to the tip of the shaft

Mobile

6191510 Hydraulic mounting kit Comfort: hammer, shears, sorting grab plus additional circuit for 2 articulated arm or SWINGOTILT. Operation via rocker in left joystick. Joystick steering is not possible with this option. Dozer blade operation Standard.

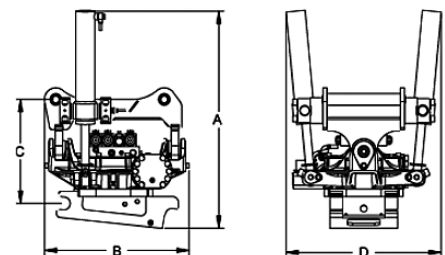

Dimensions approx.	A	B	C	D
ST15-620	1002	807	560	789
ST18-620	980	850	525	830
ST22-620	1060	910	620	850

We reserve the right to make technical changes in the course of further development! ATLAS GmbH, 27777 Ganderkesee

ATLAS GmbH - Atlas Str. 6 -27777 Ganderkesee

Tel.: +49 (0) 4222 954-0 -Fax : +49 (0) 4222 954343

Offer list: Attachments for hydraulic excavators

Ripper tooth

Material no.	Type designation	Depth	Suitable for arm width and bolts, Ø (mm), SWE (quick change device)	Recommended excavator size	Weight (kg)
6017199	H43.20		268/60	12 - 20 t	201
6016095	H43.20SW		T620V/T620H	12 - 20 t	209
4569242	H63.20		300/80	17 - 25 t	290
4568752	H63.20SW		T63.20/T63.20H	17 - 25 t	375

Heavy duty fork with 6 forked screw teeth, for picking up pave stones

Material no.	Type designation	Width	Litres	Suitable for arm width and bolts, Ø (mm), SWE (quick change device)	Recommended excavator size	Weight (kg)
3509431	J40.8	1200	400	268/60	12 - 23 t	476
3548303	J40.8 SW	1200	400	T620V/T620H	12 - 23 t	515
6162151	J40.8 MS10	1200	400	Lehnhoff MS 10	12 - 23 t	515

Load hook, capable of rotation

Material no.	Type designation	Load-bearing capacity kN	Length	Suitable for arm width and bolts, Ø (mm), SWE (quick change device)	Recommended excavator size	Weight (kg)
1907382	K11.10	75	560	168/50	6 - 11 t	30
3112272	K11.10SW	75	630	T11.10/T11.20	6 - 11 t	50
1907393	K610	150	690	268/60	12 - 23 t	50
6134786	K610-347	150	690	347/80	17 - 25 t	85
2225061	K610 SW	150	790	T610/T620/T620H	12 - 23 t	75
6150248	K610SW-T713	150	790	T713	17 - 25 t	85
4568423	K63.10	200	820	300/80	17 - 25 t	87
4568434	K63.10SW	200	960	T63.10 T63.20 T63.20H	17 - 25 t	140
0729737	K710	125	590	forked/80	22 - 35 t	85
2224935	K710SW	125	730	T722/T722H	22 - 35 t	180

Load hook fixed, incapable of rotation

3534909	K613	150	655	268/60	12 - 23 t	50
3572585	K613SW	150	655	T610/T620/T620H	12 - 23 t	60
4580429	K713	200	650	345 (closed) /80	22 - 35 t	55
5411256	K713SW	200	690	T713	22 - 35 t	78

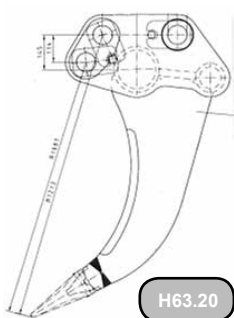

H63.20



Stegabstand 50 mm



K610



K713



K610SW



K63.10SW

We reserve the right to make technical changes in the course of further development! ATLAS GmbH, 27777 Ganderkesee

Pallet forks

Material no.	Type designation	Load-bearing capacity (t.)	Teeth length	Suitable for arm width and bolts, Ø (mm), SWE (quick change device)	Recommended excavator size	Weight (kg)
6149549	PG2,5T.ZL1250MM	2.5	1200	268/60	12 - 23 t	210
6147343	PGSW2,5T.ZL1250MM	2.5	1200	T620/T620H	12 - 23 t	330

Original load-lifting magnets MOZELT as standard with triple chain sling

Material no.	Type designation	Diameter Ø (mm)	kW	Recommended excavator size	Weight (kg)
6151212	MLA10	1020	5,5kW220VDC/80%ED		680
6063217	MLA11	1170	7,0kW220VDC/80%ED		1080
6073058	MLA12	1270	9,0kW220VDC/80%ED		1400
6068772	MLA13	1375	10,0kW220VDC/80%ED		1720
6123773	MLA15	1530	12,5kW220VDC/80%ED		2300

fixed load hook is necessary, see page 44



PGSW 2,5T.
ZL 1200mm



Load-lifting magnets
MOZELT



non-ATLAS multi-
jaw grab!!



Load-lifting magnets with a
triple chain sling

Michaelis mowing bucket

Material no.	Type designation	Cutting width	Oil level (constant)	Maximum permissible pressure	Recommended excavator size	Weight (kg)
	M 2200 G	2,20 m	22 l/min	180 bar	ab 10 t	420
	M 2500 G	2,50 m	22 l/min	180 bar	ab 10 t	490
	M 3000 G	3,00 m	22 l/min	180 bar	ab 10 t	610
	M 4000 G	4,00 m	32 l/min	180 bar	ab 10 t	740
	M 5000 G	5,00 m	48 l/min	180 bar	ab 10 t	950



(*) The weights of the bucket carriers vary depending on the type and construction of the excavator.



- For mowing work on slopes and bottom with simultaneous removal of the mowed material
- High cutting performance via gear drive
- Wear-resistant bearings and components
- Central lubrication
- Proven Michaelis cutting unit with protrusive finger bar and floating blade



The holders (bucket carriers) are available to fit the respective excavator model or the eventually existing quick-change device. Special dimensions are also available. According to the kinematics data of your excavator, we design the optimum opening angle for the mowing bucket.

The bucket carrier is swinging. The pendulous movement is damped by two rubber buffers, which results in a good adaptation to the soil conditions.



Possible accessories

Left:
silt sheets and detachable side panels

Right:
finger skids



- Work attachments - Manufacture at the factory in Vechta



Assembly station - rotation gears-



Each rotation gear is checked here before distributing to the dealers



Final assembly station of the grabs - customized assembly -



Christmas in Vechta



Loading for distributing to the customers

The right tool

We manufacture our tools in standard and special models based on the most current know-how in the fields of machine and steel construction. High-strength steels, tried and tested with century-long experience in this industry are guarantees for cost-efficient and practical work.

Capable service partners. The customer service employees of our dealers are highly trained in the technology in our factory in order to be qualified contacts for you at all times.

We reserve the right to make technical changes in the course of further development! **ATLAS GmbH**, 27777 Ganderkesee



EASY. FAST. RELIABLE.

THE RIGHT TOOL

We manufacture our tools in standard and special models based on the most current know-how in the fields of machine and steel construction.

High-strength steels, tried and tested with century-long experience in this industry are guarantees for cost-efficient and practical work.

CAPABLE SERVICE PARTNERS

The customer service employees of our dealers are highly trained in the technology in our factory in order to be qualified contacts for you at all times.

THE BEST SUPPORT

With our AEM system, you also have a reliable partner for servicing. The service menu with maintenance-interval and measurement-data display stores all required information.

A diagnostics interface in the driver's cab for the connection of a laptop enables the easy readout and configuration of the AEM system.

DAS RICHTIGE WERKZEUG

Wir fertigen unsere Werkzeuge in Serien- und Sonderausführungen nach modernsten Erkenntnissen des Maschinen- und Stahlbaus. Hochfeste Stähle, bewährte Technik und jahrzehntelange Erfahrung sind in diesem Sektor Garanten für kostengerechtes und praxisnahes Arbeiten.

KOMPETENTE SERVICEPARTNER

Die Kundendienstmitarbeiter unserer Händler werden intensiv im Bereich Technik in unserem Werk geschult, um für Sie jederzeit ein kompetenter Ansprechpartner zu sein.

BESTE UNTERSTÜTZUNG

Mit unserem AEM-System haben Sie auch bei der Wartung einen verlässlichen Partner.

Das Service-menü mit Wartungsintervall- und Messdatenanzeige hält alle erforderlichen Informationen bereit. Eine Diagnose-Schnittstelle in der Fahrerkabine zum Anschluss eines Laptops ermöglicht das leichte Auslesen und Konfigurieren des AEM-Systems.



Ganderkeseer Factory

ATLAS GmbH
Atlasstrasse 6
27777 Ganderkeseer, Germany
T: +49 (0) 4222 954 0
F: +49 (0) 4222 954 220

info@atlasgmbh.com

AVAILABLE & COST EFFECTIVE